

TIRE & TUBE SECTION

Knowing some basic facts about tire dimensions and sizes along with a few technical aspects of tire construction can help clear up much of the confusion many people have in understanding tires and tire sizes. There are up to 14 parts to a tire, and each one is subjected to different stresses and performance requirements. About 89% of a tire is rubber compound. The remainder consists of 8% ply and belt materials, and 2.5% steel wire used in the bead. Understanding the sizing of tires can be especially confusing. There are two popular methods of identifying lawn and garden tires. The first is *overall diameter x section width x rim diameter*. An example of a popular tire using these dimensions is a 16 x 650-8 tire.

The second popular method of designating tire sizes includes *section width x section height x rim diameter*, for example 4.10/3.50-4.

The section width and section height are also used to size car passenger tires. For instance, a P205/75R14 tire size is explained this way: the P stands for passenger car tire; the 205 is the section width in millimeters; the 75 indicates the section height to section width ratio (%); the R stands for radial construction; and the 14 is the rim diameter in inches.

DEFINITIONS:

- **Bead** - The inner portion of the tire which fits onto the rim and contains bands of wire to which tire plies are attached.
- **Ply Rating** - Index of tire strength; indicates maximum recommended load for specific types of service. Usually does not indicate actual number of cord plies in the tire as it did in the past.
- **Rim Diameter** - The distance between the vertical portion of the rim flange. If the rim is too wide or too narrow the tire beads will not seat properly. As a general rule, the proper rim width for a tire will be 1/2 to 1 1/2 inches narrower than the section width of the tire, depending on the size of the tire.
- **Section Width** - The distance across a tire at its widest part when inflated but not under load (does not include protective bars or decorations).
- **Section Height** - The distance between tread crown and bead seat when tire is inflated but not under load.
- **Tire & Rim Association** - An organization of manufacturers which develops standards for rim and tire dimensions, loads and inflation pressures.

The Tire & Rim Association has set an acceptable variance of 8% from their published dimensions for tire size designations. Because of this variance it is always prudent to be aware of the possibility of tread and dimensional differences when replacing tires. This becomes especially important when replacing tires on equipment where tire dimensions are critical to equipment performance.

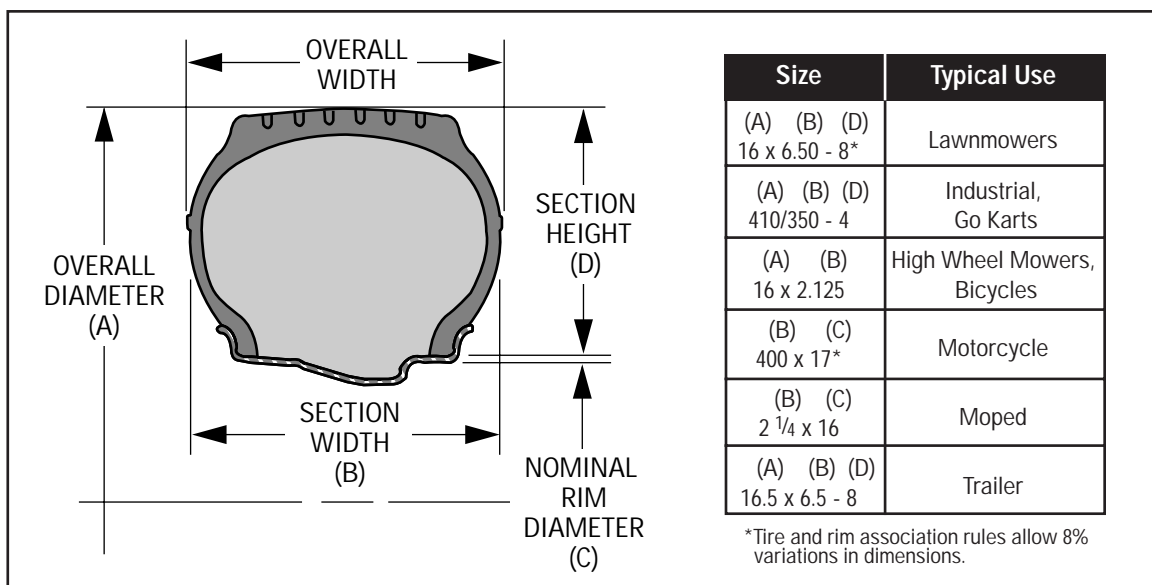

PNEUMATIC TIRES (NON-HIGHWAY SERVICE)

APPLICATIONS:
Lawn & Garden • Wheelbarrows
Material Handling • Industrial
Go-Karts

PNEUMATIC TIRES

Size Inches	Type	Ply Rating	Tread	Aprox. Dia. Inches	Aprox. Width Inches	Wt. Lbs.	Capacity Lbs.	PSI	Part Number
280/250-4	TT	2	Lug	8.9	2.8	1.2	200	36	TC-028
		4	Universal	8.9	2.8	1.2	260	50	TC-029
		4	Univ. (Grey)	8.9	2.8	1.2	260	50	TC-029G
		4	Univ. (125 PSI)	8.9	2.8	1.2	295	125	TC-029H
8 x 300-4	TT	4	Slick	8.0	3.0	1.5	210	50	TC-337
9 x 350-4	TL	2	Turf	9.0	3.5	2.5	230	36	TC-047
			Turf (Grey)	9.0	3.5	2.5	230	50	TC-047G
		4	Slick	9.0	3.5	2.5	350	36	TC-039
410/350-4	TT	2	Sawtooth	10.6	4.0	2.0	230	36	TC-036
		4	Sawtooth (Grey)	10.6	4.0	2.0	350	50	TC-036G
		4	Sawtooth	10.6	4.0	2.0	350	85	TC-436
	TL	2	Sawtooth	10.6	4.0	2.0	230	36	TC-044
				350	50	TC-444			
	TT	2	Universal	10.6	4.0	2.0	230	36	TC-042
				230	36	TC-042TL			
	TT	4				350	50	TC-043	
	TT	2	Stud	10.6	4.0	2.0	230	36	TC-030
				230	36	TC-032			
	TL	2	Turf	10.6	4.0	2.0	230	36	TC-034
	TT	2	Knobby	10.6	4.0	2.0	230	36	TC-033
340/300-5	TT	2	Universal	10.7	3.5	2.0	200	50	TC-054
							305	100	TC-050
		4	Slick (3")	10.5	3.0	2.0	305	20	TC-057
410/350-5	TT	2	Universal	11.6	4.0	2.5	205	40	TC-051
							445	85	TC-052
	TT	2	Stud	11.6	4.0	2.5	285	40	TC-045
							285	40	TC-045TL
	TT	2	Knobby	11.6	4.0	2.5	285	40	TC-048
	TT	2	Slick (3 1/2")	11.0	3.5		285	20	TC-055
				11.0	4.5		285	20	TC-053
11 x 350-5	TT	4	Slick (3 1/2")	11.0	3.5	2.8	260	20	TC-056
11 x 360-5 (Heavy)	TT	4	Slick (3 1/2")	11.0	3.5	3.0	305	30	TC-357
11 x 4.00-5	TL	2	Linear Rib	10.7	4.1	2.8	200	20	TC-021
							320	20	TC-421
		2	Turf	10.7	4.1	2.8	200	20	TC-059
11 x 4.50-5	TT	2	Slick (4 1/2")	11.0	4.5	3.0	210	20	TC-058
12 x 4.00-5 (Heavy)	TT	4	Slick (4")	12.0	4.0	4.5	320	20	TC-355

CHART CONTINUED ON NEXT PAGE.

92©1999 Magnus Mobility Systems Inc. All rights reserved



Lug



Universal



Slick



Sawtooth



Stud

PNEUMATIC TIRES (NON-HIGHWAY SERVICE)

PNEUMATIC TIRES (Continued)

Size Inches	Type	Ply Rating	Tread	Aprox. Dia. Inches	Aprox. Width Inches	Wt. Lbs.	Capacity Lbs.	PSI	Part Number
410/350-6	TT	2	Sawtooth	12.6	4.0	3.0	290	40	TC-073
		4					445	85	TC-074
	TL	2	Universal	12.6	4.0	3.0	290	40	TC-095
	TT	2					290	40	TC-076
	TT	2	Stud	12.6	4.0	3.0	290	40	TC-061
							TL	290	40
	TT	2	Knobby	12.6	4.0	3.0	290	40	TC-064
12 x 6.00-6	TT	2	Slick (5 1/2")	12.0	5.5	5.0	400	30	TC-072
13 x 4.00-6 (Heavy)	TT	2	Slick	13.0	4.0	4.5	295	30	TC-371
13 x 5.00-6	TL	2	Linear Rib	12.6	4.8	3.5	295	20	TC-023
		4					440	40	TC-423
		2	Turf	12.6	4.8	3.5	295	20	TC-022
		4					440	40	TC-027
13 x 6.50-6	TL	4	Linear Rib	12.7	6.5	4.2	460	28	TC-301
		2	Turf	12.7	6.5	4.5	305	14	TC-302
		4				4.8	460	28	TC-402
		4	Smooth	12.7	6.5	4.5	460	28	TC-300
530/450-6	TT	2	Universal	14.7	5.3	4.3	450	30	TC-075
		4					710	65	TC-070
		2	Stud	14.7	5.3	4.3	450	30	TC-369
		4					Knobby	14.7	5.3
400-6	TL	2	10 Rib	13.7	4.5	2.7	260	35	TC-060
15 x 6.00-6	TL	2	Linear Rib	14.4	6.1	4.9	365	14	TC-078
		4				5.0	740	24	TC-478
		2	Turf	14.4	6.1	4.9	365	14	TC-090
		4				5.0	740	14	TC-490
800-6	TT	4	Linear Rib	17.8	8.0	7.5	740	24	TC-077
300-8	TL	2	10 Rib	16.0	3.2	2.0	300	30	TC-037
350-8	TL	2	10 Rib	15.0	3.5	2.5	340	30	TC-063
	TT	4	Knobby	15.0	3.5	2.9	390	40	TC-381
480/400-7	TT	4	Stud	14.7	4.1	3.7	470	30	TC-922
400-8 (Wheelbarrow)	TL	2	10 Rib	16.0	4.6	3.0	435	30	TC-002
	TT						380	30	TC-000
	TT	4	Smooth (Roofers)	16.0	4.6	3.0	670	30	TC-001
	TL	2					435	30	TC-004
480/400-8	TT	2	Stud	16.6	4.8	4.4	505	35	TC-011
	TL							TC-011TL	
	TL	2	AGR	16.6	4.8	6.0	435	20	TC-010

CHART CONTINUED ON NEXT PAGE.



Turf



Knobby



Linear Rib



10 Rib



AGR

PNEUMATIC TIRES (NON-HIGHWAY SERVICE)

PNEUMATIC TIRES (Continued)

Size Inches	Type	Ply Rating	Tread	Aprox. Dia. Inches	Aprox. Width Inches	Wt. Lbs.	Capacity Lbs.	PSI	Part Number
16 x 6.50-8	TL	2	Linear Rib	16.0	6.5	6.0	415	14	TC-015
		4				7.0	620	28	TC-046
	TL	2	Turf	16.0	6.5	6.5	415	14	TC-014
		4				8.0	620	28	TC-009
	TL	4	AGR	16.0	6.5	7.0	620	28	TC-800
16 x 7.50-8	TL	4	Turf	16.2	7.2	24.0	710	24	TC-710
18 x 6.50-8	TL	2	Turf	18.0	6.5	9.4	815	22	TC-802
18 x 8.50-8	TL	2	Rib	18.0	8.5	8.0	515	10	TC-016
		4					815	22	TC-018
	TL	2	Turf	18.0	8.5	9.0	515	10	TC-017
	TL	2	Turf RS*	18.0	8.5	8.5	515	10	TC-217
	TL	4	Turf	18.0	8.5	9.0	815	22	TC-049
18 x 9.50-8	TL	4	Rib	18.2	9.3	11.0	1040	24	TC-097
		2	Turf	18.2	9.3	9.0	695	12	TC-806
		2	AGR	18.2	9.3	11.0	695	12	TC-810
570-8	TT	4	Extra Grip	18.6	5.8	11.0	980	60	TC-812
20 x 10.00-8	TL	2	Turf RS*	20.2	9.8	9.8	730	10	TC-814
		4				13.3	800	20	TC-816
20 x 8.00-10	TL	2	Turf RS*	19.5	7.6	10.0	595	12	TC-818
20 x 10.00-10	TL	2	Turf RS*	20.1	9.5	12.0	680	10	TC-720
		4				13.0	1080	22	TC-730
6-12	TT	2	AGR	24.4	6.8	14.0	395	14	TC-558
23 x 8.50-12	TL	2	Turf	22.6	8.4	15.0	705	10	TC-750
		4				18.0	1115	22	TC-760
	TL	2	Turf RS*	22.6	8.4	15.0	705	10	TC-551
		4				18.0	1115	22	TC-561
23 x 9.50-12	TL	2	Turf	22.6	9.5	16.0	705	15	TC-552
23 x 10.50-12	TL	2	Turf RS*	22.8	10.4	17.0	1340	20	TC-553
		4				18.0	890	15	TC-563

*Round Shoulder



Turf



Turf RS
(Round Shoulder)



Smooth



Extra Grip



AGR

LOW SPEED RIMS AND HUBS (NON-HIGHWAY SERVICE)

ONE PIECE DROP CENTER (For Tubeless Tires)

Rim Dia. Inches	Rim Width Inches	Hub Length Inches	Hub Center Or Offset	Fits Tire Size	Weight Lbs.	Part Number
4	2 1/4	3.0	Center	250-4, 280/250-4	1.5	DC400
		2.25	Offset			DC410
		3.25	Offset			DC420
5	3 1/4	3.25	Center	410-5, 11 x 400-5	3.0	DC500
6	3 1/4	3.0	Center	410/350-6, 13 x 500-6	3.0	DC600
		3.5	Center			DC610
		4 1/2	Offset		4.5	DC620
8	2 3/4	3.5	Center	480-8, 400-8	4.5	DC800
		4.0	Offset			DC810
		6.0	Center			DC820
	3 1/4	3.0	Center	480-8, 570-8, 650-8	5.0	DC830
	5 3/8	4.0	Offset	650-8, 850-8	6.5	DC840
	8	3.25	Center	1100-8, 1200-8	8.0	DC850

To order with bearing, specify size (i.e. DC400-5/8")

3 PIECE DEMOUNTABLE RIM AND HUB

Rim Dia. Inches	Rim Width Inches	Hub Length Inches	Hub Center Or Offset	Fits Tire Size (Tube Required)	Weight Lbs.	Part Number
4	1 3/4	2.25	Offset	200-4, 280/250-4	1.5	DC401
		2.5	Center			DC403
	2 1/4	3.0	Center	9 x 350-4 410/350-4	2.0	DC405
		3.75	Center			DC407
	2 3/4	2.25	Offset			DC409
		3.25	Offset			DC411
5	2 3/4	2.5	Offset	340/300-5, 11 x 350-5	3.5	DC501
	3 1/4	3.5	Center	11 x 400-5, 410/350-5		DC503
6	3 1/4	3.0	Center	410/350-6	3.5	DC601*
		4.0	Center	13 x 500-6, 530/450-6		DC603*
	4 1/2	3.5	Offset	12 x 600-6, 15 x 600-6	4.0	DC605*

To order with bearing, specify size (i.e. DC401-5/8")

*If Zirk required on 6", add suffix "ZE"

APPLICATIONS:

- Lawn & Garden
- Industrial
- Wheelbarrows
- Utility Carts
- Go Karts



One Piece Drop Center

- Ball Bearing Sizes - 1/2", 5/8" (standard), 3/4"
- Baked Enamel Finish
- For Tubeless Tires



3 Piece Demountable Rim And Hub

- Ball Bearing Sizes - 1/2", 5/8" (standard), 3/4"
- Zinc Chromate Finish
- Bolt Together Construction For Quick And Easy Maintenance
- For Tube Type Assembly

TIRES / HIGH SPEED RIMS

Highway Service

TIRES

Size Inches	Load Range	Load Cap. Lbs.	PSI	Dimensions			Tread Depth In 32nds"	Wt. Lbs.	Part No.
				OD	SW	Rim			
4.80-8	B	590	60	16.8	5.1	3.75	6	6	TC-005
5.70-8	B	715	50	18.4	5.5	3.75	7	9	TC-012
	C	910	75					11	TC-013
4.80-12	B	780	60	20.7	5.1	4.00	6	9	TC-019
5.30-12	B	840	55	21.9	5.6	4.00	6	10	TC-020
	C	1045	80					12	TC-038
16.5 x 6.5-8	B	620	45	16.2	6.5	5.37	6	6	TC-304
	C	795	70					6	TC-309
18.5 x 8.5-8	B	770	35	18.2	8.4	7.0	10	10	TC-305
	C	940	50					14	TC-306
20.5x8.0-10	B	905	35	20.4	8.0	6.0	10	13	TC-338
	C	1105	50					14	TC-339
	D	1330	70					16	TC-340
	E	1535	90					17	TC-341
B78-13 ST	B	1065	35	24.7	6.7	4.5	10	14	TC-701



4 BOLT ON 4" BOLT CIRCLE

Rim Dia. Inches	Rim Width Inches	Pilot Hole Inches	Fits Tire Size	Weight Lbs.	Part Number
8	3 3/4	2.50	480-8, 570-8	4.5	DC-401
	5 3/8	2.50	16.5-8	5.8	DC-403
	7	2.50	18.5-8	6.0	DC-419
10	6	2.50	20.5-10	9.8	DC-431
12	4	2.50	480-12, 530-12	10.3	DC-411
12 (Spoked)	4	2.50	480-12, 530-12	10.1	DC-411S
13	4 1/2	2.82	A78-13, B78-13	13.5	DC-434



Plain Style

5 BOLT ON 4 1/2" BOLT CIRCLE

Rim Dia. Inches	Rim Width Inches	Pilot Hole Inches	Fits Tire Size	Weight Lbs.	Part Number
8	3 3/4	2.82	480-8, 570-8	4.5	DC-404
	5 3/8	2.82	16.5-8	5.8	DC-413
	7	2.82	18.5-8	6.0	DC-417
10	6	2.82	20.5-10	9.8	DC-432
12	4	2.75	480-12, 530-12	10.3	DC-414
12 (Spoked)	4	2.75	480-12, 530-12	10.1	DC-414S
13 (Spoked)	4 1/2	2.95	A78-13, B78-13	13.2	DC-418S



Spoked Style

HIGH SPEED RIMS

One Piece Drop Center Construction

INTEGRAL HUBS (One Cap, One Seal Standard)

Rim Dia. Inches	Rim Width Inches	Tapered Bearing Inches	Fits Tire Size	Weight Lbs.	Part Number
8	3 3/4	3/4	480-8, 570-8	6.25	IH-81
	3 3/4	1	480-8, 570-8	6.75	IH-83

1" high speed tapered bearing x 4 1/8" hub length, 2 7/16" distance between races.
 3/4" high speed tapered bearing x 4 1/8" hub length, 2 1/16" distance between races.



Integral Style
Complete with bearings

TRAILER TIRE AND WHEEL ASSEMBLIES

(Light Duty or Utility) Fixed Hub Integral

Size Inches	Bearing Inches	Load Range	Maximum Load Capacity @ PSI	Weight Lbs.	Part Number
480-8	3/4	B	590 @ 60	13	TC-005-HS
	1	C	745 @ 90	14	TC-007-HS
570-8	3/4	B	715 @ 50	14	TC-012-HS
	1	C	910 @ 75	15	TC-013-HS

Supplied with one seal, one cap.
 1" high speed tapered bearing x 4 1/8" hub length, 2 7/16" distance between races.
 3/4" high speed tapered bearing x 4 1/8" hub length, 2 1/16" distance between races.



Fixed
Integral Hub

POPULAR BOAT & CAMPING TRAILER ASSEMBLIES

Size Inches	Load Range	Rim Style	# of Lug Bolts	Bolt Circle Inches	Pilot Hole Inches	Max. PSI	Capacity Lbs.	Wt. Lbs.	Part Number
480-8	B	Plain	4	4	2.50	60	590	11.5	DC-4800-4
			5	4 1/2	2.82				DC-4800-5
570-8	B	Plain	4	4	2.50	50	715	14.1	DC-5700-4
			5	4 1/2	2.82				DC-5700-5
16.5x6.5x8	C	Plain	4	4	2.50	70	795	12.8	DC-1658-4
			5	4 1/2	2.82				DC-1658-5
18.5x8.5x8	C	Plain	4	4	2.50	50	940	20.0	DC-1858-4
			5	4 1/2	2.82				DC-1858-5
20.5x8.5x10	C	Plain	4	4	2.50	50	1105	24.9	DC-2058-4
			5	4 1/2	2.82				DC-2058-5
480-12	C	Spoked	4	4	2.50	90	990	20.5	DC-1210-4S
			5	4 1/2	2.75				DC-1210-5S
530-12	C	Spoked	4	4	2.50	80	1045	22.7	DC-1220-4S
			5	4 1/2	2.75				DC-1220-5S
B78-13 ST	B	Spoked	4	4	2.82	35	1065	29.2	DC-1310-4S
			5	4 1/2	2.95				DC-1310-5S



HUBS & SPINDLE

HIGH SPEED TRAILER HUBS

(1/2" Studs, Tapered Roller Bearings)

Bolt Circle	Tapered Bearing Inches	Hub Length Inches	Load Capacity Lbs.	Weight Lbs.	Part Number
4 on 4"	1	4 1/8	1000	4.0	H4-1
5 on 4 1/2"	1	4 1/8	1000	4.0	H5-1



SPINDLE

Description	Load Capacity Lbs.	Part Number
1" x 8 1/2" Long	1000	SP-1



SLOW SPEED HUBS (NHS)

Fits any 4 Hole Rim On 4" Centers

Description	Hub Length Inches	Weight Lbs.	Part Number
4 Bolt Hub (For 1/2", 5/8", or 3/4" Ball Bearing)	3	3.25	S4-30
	3 1/2	3.5	S4-35
	4	3.5	S4-40
	6	3.8	S4-60
4 Bolt Hub (3/4" Plain Bore, 3/16" Keyway)	3 1/2	3.25	K4-35
4 Bolt Hub (1" Plain Bore, 1/4" Keyway)	3 1/4	3.25	K4-33



Ball Bearing Type



Keyway Type

BALL BEARINGS

Bearing I.D. Inches	Bearing O.D. Inches	Overall Length Inches	Part Number
3/8	1 3/8	7/16	BB-062200
7/16	1 3/8	7/16	BB-072200
1/2	1 1/8	7/16	BB-081800
	1 3/8	7/16	BB-082200
9/16	1 3/8	7/16	BB-092200
5/8	1 3/8	7/16	BB-102200
5/8 (Precision)	1 3/8	7/16	BB-102200P
3/4	1 3/8	7/16	BB-122200



Flanged Type



Precision Type (Sealed) With Snap Ring

TUBES

APPLICATIONS:
Slow & High Speed Use

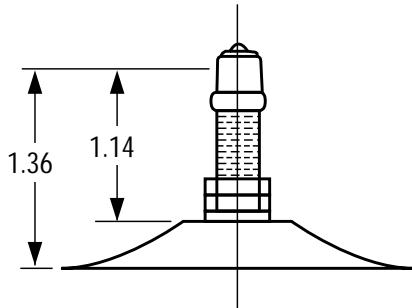

TR 6

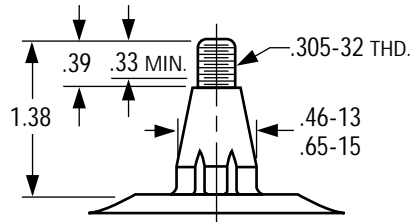

TR 13 & 15

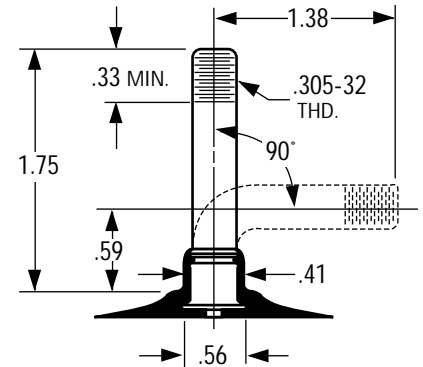

TR 87
JS87P Bent 45°

Tube Size	Valve	Description	Wt. Lbs.	Part Number
200 x 50	TR87 (90°)	Tube	.5	TU-141
280 x 250-4	TR87	Tube (9x350-4)	.5	TU-129
	JS87P	Tube (9x350-4)	.5	TU-129J
410/350-4	TR87	Tube	.5	TU-130
	JS87P	Tube	.5	TU-130J
	TR13 (Straight)	Tube (Note straight valve)	.5	TU-131
340/300-5	TR87	Tube	.5	TU-147
410/350-5	TR87	Tube	.5	TU-145
	TR13	Tube (Note straight valve)	.5	TU-150
400-5	TR87	Tube (11x400-5)	1.0	TU-146
11 x 600-5	TR87	Tube	1.0	TU-148
410/350-6	TR87	Tube (400-6)	1.0	TU-161
	TR13	Tube (Note straight valve)	1.0	TU-165
13 x 500-6	TR87	Tube (14x6) (530/450-6)	1.0	TU-162
	TR13	Tube (Note straight valve)	1.0	TU-166
600-6	TR87	Tube (12x600-6)	1.0	TU-164
13 x 650-6	TR13	Tube	1.0	TU-168
	TR87	Tube	1.0	TU-168S
15 x 600-6	TR13	Tube	1.0	TU-163
	TR87	Tube	1.0	TU-163S
800-6/7	TR87C	Tube	2.0	TU-167
400-7	TR13	Tube	1.0	TU-171
16 x 800-7	TR6	Tube	2.0	TU-113
300-8	TR13	Tube	.5	TU-102
400-8	TR13	Tube (350x8) (For low speed use)	1.0	TU-100
480/400-8	TR13	Tube (For high speed use)	1.0	TU-105
	JS87C	Tube	1.0	TU-106

Tube Size	Valve	Description	Wt. Lbs.	Part Number
570/500-8	TR13	Tube	1.5	TU-107
	JS2	Tube	1.5	TU-109
16 x 650-8	TR13	Tube	1.0	TU-108
18 x 850-8	TR13	Tube (18x950-8)	1.5	TU-110
20 x 700-8	TR6	Tube	2.0	TU-115
22 x 1100-8	TR6	Tube (21x1200-8)	2.5	TU-111
400-9	TR13	Tube	1.0	TU-172
600-9	TR13	Tube	2.0	TU-114
	JS2	Tube	1.5	TU-909
25 x 1200-9	TR6	Tube	3.0	TU-112
350-10	TR13	Tube (400-10)	1.0	TU-122
650-10	JS2	Tube	2.0	TU-910
20.5 x 8.0-10	TR13	Tube (20x8.00-10)	2.0	TU-923
23.5 x 800-11	TR6	Tube	2.5	TU-189
480-12	TR13	Tube	1.0	TU-124
530-12	TR13	Tube	1.5	TU-125
600-12	TR13	Tube	2.0	TU-128
700-12	TR75A	Tube	3.5	TU-912
23 x 850-12	TR13	Tube (23x1050-12) (23x950-12)	3.0	TU-126
26 x 12-12	TR13	Tube	3.0	TU-169
16 x 2.125	S.V.	Tube High Wheel Mower/Cart	.5	TU-316
		Tube (Thornproof)	1.0	TU-440
20 x 2.125	S.V.	Tube High Wheel Mower/Cart	.5	TU-320
		Tube (Thornproof)	1.0	TU-442
26 x 2.125	S.V.	Tube High Wheel Mower/Cart	.5	TU-326
		Tube (Thornproof)	1.0	TU-446