

FULL-PNEUMATIC WHEEL ASSEMBLIES (PN)

Capacities to 675 lbs.

Standard Features

- 3-Piece Demountable Wheels
- Tube Type
- Zerk Fitting On Hub
- Ball or Roller Bearing

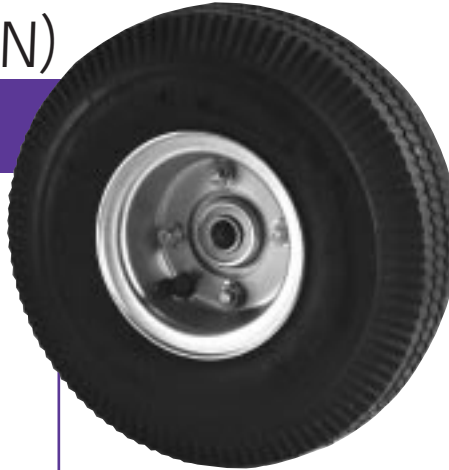

APPLICATIONS:

- Hand Trucks
- Dollies
- Replacement Wheels for Pneumatic Casters (page ?)
- Pneumatic Assemblies Offer Smoothest Ride Over Rough Terrain

Optional Features

- Polyurethane Foam Fill (Suffix-PF)
- Gray Non-Marking Tire 8" & 10" (Suffix-G)
- Many Other Tire & Wheel Combinations Available

Size Inches	Hub	Hub Length Inches	Ply	Bearing Type	Bearing Size Inches	Capacity Lbs.	Weight Lbs.	Notes	Part Number
8 (280/250 x 4)	Centered	3 1/2	4	Ball	3/4	295	4.0	Replacement Wheel for Caster #S183B-PN	8PN-B
	Centered	3 1/4	4	Roller	3/4	295	4.2	Replacement Wheel for Caster #S183R-PN & S683R-PN	8PN-R
10 (410/350 x 4)	Offset	2 1/4	2	Ball	5/8	260	5.0	Standard Replacement for Hand Truck	10PN
	Centered	3 1/2"	2	Ball	3/4	260	5.1	Replacement Wheel for Caster #S1103B-PN	10PN-B
	Centered	3 1/2"		Roller	3/4	410	5.4	Replacement Wheel for Caster #S1103R-PN & S6103R-PN	10PN-R
12 (410/350 x 6)	Centered	4 1/4	2	Ball	3/4	295	6.0	Replacement Wheel for Caster #S1123B-PN	12PN-B
	Centered	4 1/4	4	Rib	3/4	675	6.3	Replacement Wheel for Caster #S1123R-PN & S6123R-PN	12PN-R

Ball bearings standard. Available in 1/2", 5/8", and 3/4"

*Specify hub length and bearing size.

SEMI-PNEUMATIC WHEELS (SN)

Capacities to 600 lbs.

APPLICATIONS:

- Hand Trucks
- Dollies
- Other Sizes Available
- 8 x 2.50, 10 x 2.75, 12 x 3.0 Sizes have injection molded cores for impact resistance. All others have pressed steel cores.

Size Inches	Hub	Hub Length Inches	Tread	Capacity Lbs.	Weight Lbs.	Part Number
5 x 1.25*	Offset	1 3/8	Rib	30	.6	SN-512
6 x 1.50*	Centered	1 3/8	Rib	50	.7	SN-613
	Offset	1 1/2	Rib	50	.7	SN-616
7 x 1.50*	Offset	1 3/8	Diamond	55	.8	SN-712
	Centered	1 3/4	Rib	55	.8	SN-715
8 x 1.75*	Offset	1 3/8	Diamond	60	.9	SN-812
	Centered	1 3/4	Rib	60	.9	SN-816
8 x 2.50**	Offset	2 1/4	Rib	275	2.0	SN-825
10 x 2.75**	Offset	2 1/4	Rib	300	3.5	SN-105
12 x 3.0**	Centered	3 1/4	Rib	600	6.0	SN-123

Ball bearings standard.

*1/2" Bore Ball Bearing **5/8" or 3/4" Bore Ball Bearing



SANTOPRENE® (SP)

Capacities to 700 lbs.

Standard Features

- **Composition** - Non marking grey tread on polyolefin core
- **Tread And Hub** - Double bonded and mechanically interlocked
- **Resistant To Chemicals, Caustics, And Mild Acids**
- **Temperature Range Of -40° to 230°F**
- **Nylon Sealed Washers** - On all roller bearing wheels

APPLICATIONS:

Light to light medium duty institutional environments such as schools, hospitals, etc.

Also suitable for medium heavy applications where non marking tread is required.

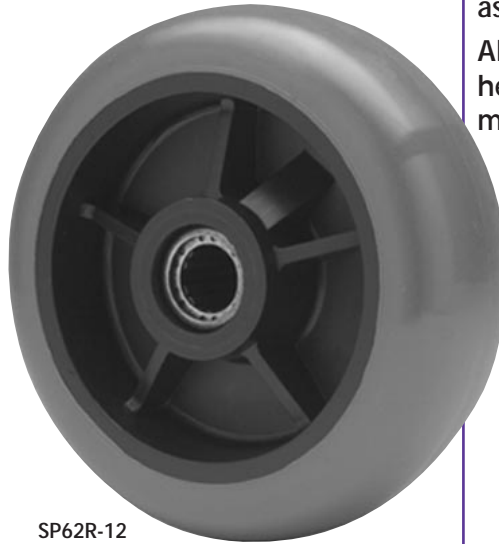

SP62R-12



SP5B-06



SP510P-05

Dia. Inches (mm)	Face Inches (mm)	Hub Length Inches (mm)	Load Capacity lbs (KGS)	Wt. lbs. (KGS)	Ball Bearing		Roller Bearing		Delrin Bearing	
					Part No.	Sizes	Part No.	Sizes	Part No.	Sizes
2 1/2 (60)	1 3/16 (21)	1 1/64 (26)	100 (45)	.25 (.10)	—	—	—	—	SP2510P-04	1/4
	1 3/8 (35)	1 9/16 (40)	140 (63)	.25 (.10)	SP25B-06	5/16, 3/8, 1/2	—	—	SP25D-06	3/8, 1/2
3 (76)	1 3/16 (21)	1 5/32 (29)	90 (40)	.2 (.20)	—	—	—	—	SP310P-04	1/4
	1 3/8 (35)	1 9/16 (40)	170 (77)	.5 (.20)	SP3B-06	3/8, 1/2	—	—	SP3D-06	3/8, 1/2
3 1/2 (89)	1 3/8 (35)	1 9/16 (40)	180 (81)	.3 (.14)	SP35B-06	3/8, 1/2	—	—	SP35D-06	3/8, 1/2
4 (102)	1 5/16 (24)	1 5/32 (29)	115 (52)	.25 (.10)	—	—	—	—	SP410P-05	5/16
	1 3/8 (35)	1 9/16 (40)	200 (90)	.3 (.14)	SP4B-06	3/8, 1/2	—	—	SP4D-05	3/8, 1/2
	2 (50)	2 3/16 (56)	350 (158)	1.2 (.54)	—	—	SP42R-12	1/2, 5/8, 3/4	SP42D-12	1/2, 5/8, 3/4
5 (127)	1 5/16 (24)	1 5/32 (29)	125 (56)	.3 (.30)	—	—	—	—	SP510P-05	5/16
	1 3/8 (35)	1 9/16 (40)	225 (101)	1.0 (.45)	SP5B-06	3/8, 1/2	—	—	SP5D-06	3/8, 1/2
	2 (50)	2 9/16 (56)	450 (203)	1.6 (.72)	—	—	SP52R-12	1/2, 5/8, 3/4	SP52D-12	1/2, 5/8, 3/4
6 (152)	1 3/8 (35)	1 9/16 (40)	250 (112)	1.2 (.54)	SP6B-06	3/8, 1/2	—	—	SP6D-06	3/8, 1/2
	2 (50)	2 3/16 (56)	550 (248)	1.7 (.76)	—	—	SP62R-12	1/2, 5/8, 3/4	SP62D-12	1/2, 5/8, 3/4
8 (203)	2 (50)	2 3/16 (56)	700 (315)	2.5 (1.1)	—	—	SP82R-12	1/2, 5/8, 3/4	SP82D-12	1/2, 5/8, 3/4

Note: 1 3/16 " and 1 5/16 " wide wheels are plain bore.

Note: Standard bearing size is called out in last two digits of part number in sixteenths (ie. SP62R-12 = 3/4" bearing, SP62R-10 = 5/8" bearing).
For smaller bore refer to spanner bushings in component parts selection (page 102).

SOFT RUBBER (SR)

Capacities to 240 lbs.

Standard Features

- **Composition** - Rubber wheel, hard core, soft tread
- **Good Floor Protection** - Quiet movement and cushioned ride
- **Temperature Range Of** - 40° to 158°F

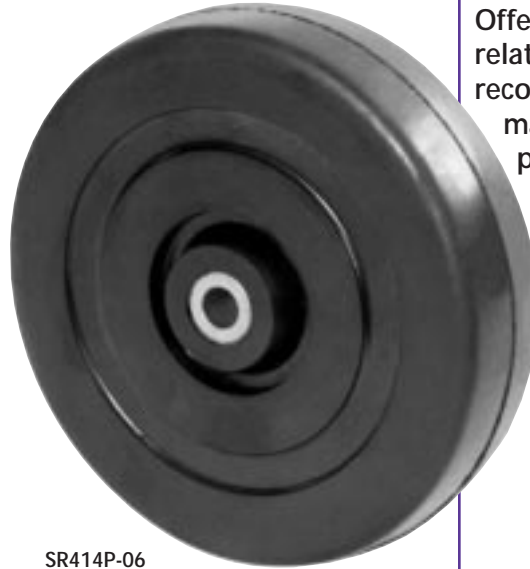

SR414P-06

APPLICATIONS:

Most popular in light, general, and light medium duty series.

Offers quiet mobility at relatively low cost. Not recommended where loads may sit static for long periods as permanent flat spotting may occur.

Dia. Inches (mm)	Face Inches (mm)	Hub Length Inches (mm)	Load Capacity lbs. (KGS)	Wt. lbs. (KGS)	Plain Bore or Bore Less Roller Bearings		Roller Bearing		Ball Bearings	
					Part No.	Sizes	Part No.	Sizes	Part No.	Sizes
1 5/8 (41)	47/64 (18)	3/4 (19)	70 (31)	.05 (.14)	SR158P-04 •	1/4	—	—	—	—
2 (50)	7/8 (22)	15/16 (24)	80 (36)	.07 (.14)	SR278P-04 •	1/4	—	—	—	—
	1 (25)	1 1/64 (26)	90 (40)	.1 (.16)	SR210P-04 •	1/4	—	—	—	—
2 1/2 (63)	1 1/8 (28)	1 3/8 (35)	100 (45)	.2 (.2)	SR25P-05 •	5/16	—	—	—	—
3 (76)	13/16 (21)	1 1/64 (26)	90 (40)	.2 (.54)	SR310P-04 •	1/4	—	—	—	—
	1 1/4 (32)	1 9/16 (40)	175 (79)	.25 (.45)	SR314P-06 •	3/8	SR314R-08	1/2	SR314B-06	3/8
3 1/2 (89)	1 5/16 (33)	1 9/16 (40)	200 (90)	.4 (.72)	SR35P-06 •	3/8	—	—	SR35B-06	3/8
4 (102)	15/16 (24)	1 5/32 (29)	115 (52)	.25 (.76)	SR410P-05 •	5/16	—	—	—	—
	1 1/4 (32)	1 9/16 (40)	200 (90)	.4 (1.1)	SR414P-06 •	3/8	SR414R-08	1/2	SR414B-06	3/8
	1 5/8 (41)	1 15/16 (49)	240 (108)	.6 (.14)	SR415P-07*	7/16	SR415R-10	5/8	—	—
5 (127)	15/16 (33)	1 5/32 (29)	125 (56)	.3 (.54)	SR510P-05 •	5/16	—	—	—	—
	1 1/4 (32)	1 9/16 (40)	200 (90)	1.7 (.45)	SR514P-06 •	3/8	SR514R-08	1/2	SR514B-06	3/8

• Supplied with celcon bushing designed to run directly on axle.

* Supplied with oil impregnated sintered iron bushing designed to run directly on axle.

MOLD-ON RUBBER (MR)

Capacities to 3,020 lbs.

Standard Features

- **Composition** - Cushioned rubber tread permanently vulcanized to cast iron cores
- **Recommended For** - Quiet movement with medium to heavy loads or where cushioning load is required
- **Temperature Range Of** -30° to 160°F
- **Tread Hardness** - 70 to 75 dur. shore A
- **Nylon Sealed Washers** - On all 1 1/2" and 2" wide wheels
- **Zerk Fitting In Hub** - Except 3 1/4" & 4" x 1 1/2"



MR62R-12

Optional Features

- **Roller Bearing Seals** - (Suffix -SW)
- **Tapered Bearing Seals** - Consult factory
- **Special Bore Sizes, Keyways, Set Screws** - Consult factory

APPLICATIONS:

Warehouse environments where floor protection and noise reduction are required.

Soft rubber tread rolls over floor joints and small obstructions quietly and smoothly.



MR83T-12

Dia. Inches (mm)	Face Inches (mm)	Hub Length Inches (mm)	Load Capacity lbs. (KGS)	Wt. lbs. (KGS)	Plain Bore or Bore Less Roller Bearing		Roller Bearing		Tapered Roller Bearing	
					Part No.	Sizes	Part No.	Sizes	Part No.	Sizes
3 1/4 (83)	1 1/2 (38)	1 5/8 (41)	140 (63)	1.0 (.45)	MR31-19	1 3/16	MR31R-12	1/2, 5/8, 3/4	—	—
4 (102)	1 1/2 (38)	1 5/8 (41)	250 (113)	1.25 (.6)	MR41-19	1 3/16	MR41R-12	1/2, 5/8, 3/4	—	—
	2 (50)	2 3/16 (56)	350 (157)	1.5 (.7)	MR42-19	1 3/16	MR42R-12	1/2, 5/8, 3/4	—	—
5 (127)	1 1/2 (38)	1 5/8 (41)	300 (135)	1.5 (.7)	MR51-19	1 3/16	MR51R-12	1/2, 5/8, 3/4	—	—
	2 (50)	2 3/16 (56)	400 (180)	2.0 (.9)	MR52-19	1 3/16	MR52R-12	1/2, 5/8, 3/4	—	—
6 (152)	1 1/2 (38)	1 5/8 (41)	300 (135)	2.0 (.9)	MR61-19	1 3/16	MR61R-12	1/2, 5/8, 3/4	—	—
	2 (50)	2 3/16 (56)	410 (184)	2.3 (1.0)	MR62-19	1 3/16	MR62R-12	1/2, 5/8, 3/4	—	—
	2 1/2 (63)	2 3/4 (70)	540 (243)	8.5 (4.0)	MRS625-19	1 3/16	MRS625R-12	3/4	—	—
	2 1/2 (63)	2 3/4 (70)	540 (243)	9.0 (4.1)	MRS625-31	1 15/16	MRS625R-16	1, 1 1/4	MR625T-12	3/4
7 (178)	3 (76)	3 1/4 (83)	680 (306)	9.5 (4.3)	MR63-31	1 15/16	MR63R-16	1, 1 1/4	MR63T-12	3/4
	2 (50)	2 3/16 (56)	460 (207)	6.0 (2.7)	MR72-23	1 7/16	MR72R-12	3/4, 7/8, 1	—	—
	2 1/4 (57)	2 3/4 (70)	530 (238)	7.0 (3.2)	MRS725-23	1 7/16	MRS725R-16	3/4, 7/8, 1	—	—
8 (203)	3 (76)	3 1/4 (83)	770 (346)	12.0 (5.4)	MR73-31	1 15/16	MR73R-16	1, 1 1/4	—	—
	2 (50)	2 3/16 (56)	500 (225)	7.0 (3.2)	MR82-19	1 3/16	MR82R-12	1/2, 5/8, 3/4	—	—
	2 1/2 (50)	2 3/4 (70)	670 (301)	10.0 (4.5)	MRS825-19	1 3/16	MRS825R-12	3/4	—	—
	2 1/2 (50)	2 3/4 (70)	670 (301)	10.0 (4.5)	MRS825-31	1 15/16	MRS825R-16	1, 1 1/4	MRS825T-12	3/4
9 (229)	3 (76)	3 1/4 (83)	840 (378)	13.0 (5.0)	MR83-31	1 15/16	MR83R-16	1, 1 1/4	MR83T-12	3/4, 1 1/4
	2 (50)	2 3/16 (56)	550 (247)	8.0 (3.6)	MR92-23	1 7/16	MR92R-12	3/4, 7/8, 1	—	—
	2 1/2 (63)	2 3/4 (70)	720 (324)	11.0 (5.0)	MRS925-31	1 15/16	MRS925R-16	1, 1 1/4	—	—
10 (254)	3 (76)	3 1/4 (83)	930 (418)	14.0 (6.3)	MR93-31	1 15/16	MRS93R-16	1, 1 1/4	—	—
	2 (50)	2 3/16 (56)	650 (292)	10.0 (4.5)	MR102-23	1 7/16	MR102R-12	3/4, 7/8, 1	—	—
	2 1/2 (63)	2 3/4 (70)	790 (355)	11.0 (5.0)	MRS1025-19	1 3/16	MRS1025R-12	3/4	—	—
	2 1/2 (63)	2 3/4 (70)	790 (355)	13.0 (5.9)	MRS1025-31	1 15/16	MRS1025R-16	1, 1 1/4	—	—
	4 (102)	4 1/4 (108)	1400 (630)	25.0 (11.3)	MR104-39	2 7/16	MR104R-20	1 1/4, 1 1/2	MR104T-20	1 1/4
11 (279)	2 1/2 (63)	2 3/4 (70)	850 (382)	14.0 (6.3)	MRS1125-31	1 15/16	MRS1125R-16	1, 1 1/4	—	—
	3 (76)	3 1/4 (83)	1070 (481)	17.0 (7.7)	MR113-31	1 15/16	MR113R-16	1, 1 1/4	—	—

Dia. Inches (mm)	Face Inches (mm)	Hub Length Inches (mm)	Load Capacity lbs. (KGS)	Wt. lbs. (KGS)	Plain Bore or Bore Less Roller Bearing		Roller Bearing		Tapered Roller Bearing	
					Part No.	Sizes	Part No.	Sizes	Part No.	Sizes
12 (305)	2 1/2 (63)	2 3/4 (70)	900 (405)	15.0 (6.8)	MRS1225-31	1 15/16	MRS1225R-16	1, 1 1/4	—	—
	3 (76)	3 1/4 (83)	900 (405)	21.0 (9.5)	MR123-31	1 15/16	MR123R-16	1, 1 1/4	—	—
	3 1/2 (89)	4 1/4 (108)	1140 (513)	24.0 (10.8)	MR1235-39	2 7/16	MR1235R-20	1 1/4, 1 1/2	—	—
	4 (102)	4 1/4 (108)	1370 (616)	28.0 (12.6)	MR124-39	2 7/16	MR124R-20	1 1/4, 1 1/2	—	—
	5 (127)	5 1/4 (133)	2050 (922)	45.0 (20.0)	MR125-39	2 7/16	MR125R-24	1 1/2	—	—
14 (356)	2 1/2 (63)	2 3/4 (70)	1020 (459)	19.0 (8.6)	MRS1425-31	1 15/16	MRS1425R-16	1, 1 1/4	—	—
	3 (76)	3 1/4 (83)	1280 (576)	25.0 (11.3)	MR143-31	1 15/16	MR143R-16	1, 1 1/4	MR143T-12	3/4, 1, 1 1/4
	4 (102)	4 1/4 (108)	1810 (814)	35.0 (15.8)	MR144-39	2 7/16	MR144R-16	1 1/4, 1 1/2	—	—
16 (406)	2 1/2 (63)	2 3/4 (70)	1130 (508)	24.0 (10.8)	MRS1625-31	1 15/16	MRS1625R-16	1, 1 1/4	—	—
	3 (76)	3 1/4 (83)	1420 (639)	32.0 (14.4)	MR163-31	1 15/16	MR163R-16	1, 1 1/4	MR163T-12	3/4, 1, 1 1/4
	4 (102)	4 1/4 (108)	1990 (895)	43.0 (19.4)	MR164-39	2 7/16	MR164R-20	1 1/4, 1 1/2	—	—
	5 (127)	5 1/4 (133)	2570 (1156)	60.0 (27.0)	MR165-39	2 7/16	MR165R-20	1 1/4, 1 1/2	MR165T-20	1 1/4, 1 1/2
18 (457)	2 1/2 (63)	3 1/4 (83)	1240 (558)	29.0 (13.0)	MR1825-31	1 15/16	MR1825R-16	1, 1 1/4	—	—
	3 (76)	3 1/4 (83)	1550 (697)	37.0 (16.7)	MR183-31	1 15/16	MR183R-16	1, 1 1/4	MR183T-12	3/4, 1, 1 1/4
	3 1/2 (89)	4 1/4 (108)	1860 (837)	40.0 (18.0)	MR1835-39	2 7/16	MR1835R-20	1 1/4, 1 1/2	—	—
	5 (127)	5 1/4 (133)	2800 (1260)	70.0 (32.0)	MR185-39	2 7/16	MR185R-20	1 1/4, 1 1/2	MR185T-20	1 1/4, 1 1/2
20 (508)	3 (76)	3 1/4 (108)	1680 (756)	42.0 (19.0)	MR203-31	1 15/16	MR203R-16	1, 1 1/4	MR203T-20	1 1/4
	5 (133)	5 1/4 (133)	3020 (1359)	80.0 (36.0)	MR205-39	2 7/16	MR205R-20	1 1/4, 1 1/2	MR205T-20	1 1/4, 1 1/2

Note: Standard bearing size is called out in last two digits of part number in sixteenths (ie. MR62R-12 = 3/4" bearing, MR62R-10 = 5/8" bearing). For smaller bore refer to spanner bushings in component parts selection.

POLYURETHANE /ALUM. CORE (PA)

Capacities to 1,500 lbs.

Standard Features

- **Composition** - Light weight aluminum core
- **Mechanically Bonded Tread** - Will not separate from core
- **Tread Hardness** - 90 to 95 dur. shore A
- **Nylon Sealed Washers** - On all roller bearing wheels
- **No Zerk Fitting In This Wheel Series**
- **Temperature Range Of** -40° to 160°F
- **Crowned Tread**

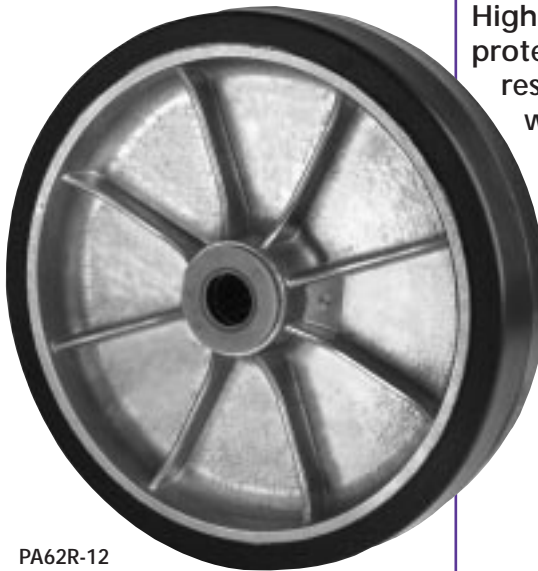

PA62R-12

APPLICATIONS:

In medium heavy duty to heavy duty cold forged casters, this is a premium offering.

High capacity, floor protection, and low rolling resistance make the PA wheel user preferred.

Dia. Inches (mm)	Face Inches (mm)	Hub Length Inches (mm)	Load Capacity lbs. (KGS)	Wt. lbs. (KGS)	Plain Bore or Bore Less Roller Bearing		Roller Bearing		Delrin Bearing	
					Part No.	Sizes	Part No.	Sizes	Part No.	Sizes
4 (102)	2 (50)	2 3/16 (56)	800 (360)	1.5 (68)	PA42-19	1 3/16	PA42R-12	1/2, 5/8, 3/4	PA42D-12	1/2, 5/8, 3/4
5 (127)	2 (50)	2 3/16 (56)	1050 (405)	1.75 (0.8)	PA52-19	1 3/16	PA52R-12	1/2, 5/8, 3/4	PA52D-12	1/2, 5/8, 3/4
6 (152)	2 (50)	2 3/16 (56)	1230 (560)	2.25 (1.0)	PA62-19	1 9/16	PA62R-12	1/2, 5/8, 3/4	PA62D-12	1/2, 5/8, 3/4
8 (203)	2 (50)	2 3/16 (56)	1500 (675)	3.25 (1.5)	PA82-19	1 9/16	PA82R-12	1/2, 5/8, 3/4	PA82D-12	1/2, 5/8, 3/4

Note: Standard bearing size is called out in last two digits of part number in sixteenths (ie. PA62-12 = 3/4" bearing, PA62R-10 = 5/8" bearing). For smaller bore refer to spanner bushings in component parts selection (page 102) 75 ©1999 Magnus Mobility Systems Inc. All Rights Reserved

ADVANCED ELASTOMER (AE)

Capacities to 1,200 lbs.



Standard Features

- **Composition** - Custom compound urethane elastomer
- **Hardness** - 65 to 68 Shore D
- **Temperature Range Of** -50° to 212°F
- **Will not flat spot**
- **Low Rolling Resistance**
- **Excellent Abrasion Resistance**



AE62B-08



AE4B-06

APPLICATIONS:
Advanced elastomer offers the highest abrasion resistance, maximum impact strength, and lowest possible rolling resistance. Withstands nearly all chemicals, greases, oils, solvents, and other compounds. No chance of tread separation caused by bond failure.

Diam. Inches (mm)	Face Inches (mm)	Hub Length Inches (mm)	Load Capacity lbs. (KGS)	Roller Bearing		Delrin Bushing		Ball Bearing		Precision Ball Brg.	
				Part No.	Sizes	Part No.	Sizes	Part No.	Sizes	Part No.	Sizes
3 (76)	1 1/4 (32)	1 7/16 (37)	400 (182)	-	-	AE3D-06	3/8	AE3B-06	3/8	-	-
	2 (50)	2 3/16 (56)	800 (410)	AE32R-12	3/4	-	1/2, 5/8, 3/4	AE32B-08	1/2	AE32P-08	1/2
3 1/2 (89)	1 1/4 (32)	1 7/16 (37)	400 (182)	-	-	AE35D-06	3/8	AE35B-06	3/8	-	-
4 (102)	1 1/4 (32)	1 7/16 (37)	400 (182)	-	-	AE4D-06	3/8	AE4B-06	3/8	-	-
	1 3/8 (35)	1 3/4 (44)	600 (273)	AE41R-08	3/8, 1/2	-	-	-	-	AE41P-08	3/8, 1/2
	2 (50)	2 3/16 (56)	1000 (450)	AE42R-12	3/4	AE42D-12	1/2, 5/8, 3/4	AE42B-08	1/2	AE42P-08	1/2
5 (127)	1 1/4 (32)	1 7/16 (37)	400 (182)	-	-	AE5D-06	3/8	AE5B-06	3/8	-	-
	1 3/8 (35)	1 3/4 (44)	600 (273)	AE51R-08	3/8, 1/2	-	-	-	-	AE51P-08	3/8, 1/2
	2 (50)	2 3/16 (56)	1000 (450)	AE52R-12	3/4	AE52D-12	1/2, 5/8, 3/4	AE52B-08	1/2	AE52P-08	1/2
6 (152)	1 3/8 (35)	1 3/4 (44)	600 (273)	AE61R-08	3/8, 1/2	-	-	-	-	AE61P-08	3/8, 1/2
	2 (50)	2 3/16 (56)	1000 (450)	AE62R-12	3/4	AE62D-12	1/2, 5/8, 3/4	AE62B-08	1/2	AE62P-08	1/2
8 (203)	2 (50)	2 3/16 (56)	1200 (545)	AE82R-12	3/4	AE82D-12	1/2, 5/8, 3/4	AE82B-08	1/2	AE82P-08	1/2

SOLID URETHANE (KT)

Capacities to 1,500 lbs.

Standard Features

- **Composition** - Constructed from the highest quality polyether polyurethane
- **Solid Cast Construction** - Eliminates tread separation or bond failure
- **Impact Resistance** - Highest of any floor protective wheel
- **Abrasion Resistance** - Highest of any floor protective wheel
- **Tread Hardness** - 55 dur. shore D.
- **Chemical Resistance** - Highest of any floor protective wheel
- **Temperature Range Of** -50° to 230°F
- **Nylon Sealed Washers** - On all roller bearing wheels

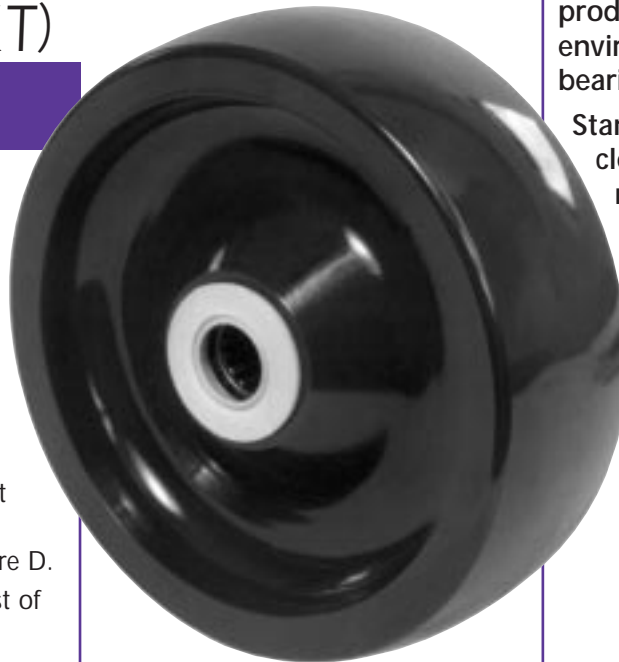

KT62R-12

APPLICATIONS:
A proven, and often preferred product in food processing, environments (with delrin bearings).

Stands up to frequent steam cleaning, exposure to moisture, and temperature variances.



KT514P-08

Dia. Inches (mm)	Face Inches (mm)	Hub Length Inches (mm)	Load Capacity lbs. (KGS)	Wt. lbs. (KGS)	Plain Bore or Bore Less Roller Bearing		Roller Bearing		Delrin Bearing	
					Part No.	Sizes	Part No.	Sizes	Part No.	Sizes
3 (76)	1 1/4 (32)	1 9/16 (40)	300 (135)	0.3 (.14)	KT314P-08	1/2	—	—	—	—
4 (102)	1 1/4 (32)	1 9/16 (40)	500 (225)	0.5 (.22)	KT414P-08	1/2	—	—	—	—
	2 (50)	2 3/16 (56)	700 (315)	1.2 (.54)	KT42-19	1 3/16	KT42R-12	3/4	KT42D-12	1/2, 5/8, 3/4
5 (127)	1 1/4 (32)	1 9/16 (40)	700 (315)	0.9 (.4)	KT514P-08	1/2	—	—	—	—
	2 (50)	2 3/16 (56)	1000 (450)	1.6 (.72)	KT52-19	1 3/16	KT52R-12	3/4	KT52D-12	1/2, 5/8, 3/4
6 (152)	2 (50)	2 3/16 (56)	1200 (540)	1.8 (.8)	KT62-19	1 3/16	KT62R-12	3/4	KT62D-12	1/2, 5/8, 3/4
8 (203)	2 (50)	2 3/16 (56)	1500 (675)	2.6 (1.2)	KT82-19	1 3/16	KT82R-12	3/4	KT82D-12	1/2, 5/8, 3/4

Note: Standard bearing size is called out in last two digits of part number in sixteenths (ie. KT62R-12 = 3/4" bearing, KT62R-10 = 5/8" bearing). For smaller bore refer to spanner bushings in component parts selection (page 102).

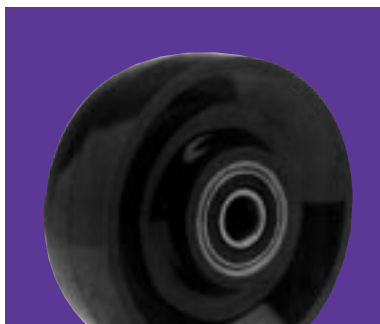

SKT825B-12

Precision ball bearings seated in Machined Steel Core. Supplied with bushings.

PRECISION BALL BEARING						
Dia. Inches (mm)	Face Inches (mm)	Hub Length Inches (mm)	Load Capacity lbs. (KGS)	Wt. lbs. (KGS)	Part No.	Sizes
6 (152)	2 (50)	2 1/4 (57)	1200 (545)	2.0 (.91)	SKT62B-08	20mm (Bushed to 1/2)
	2 1/2 (60)	2 3/4 (70)	1620 (736)	3.0 (1.4)	SKT625B-12	1" (Bushed to 3/4)
	3 (76)	3 1/4 (83)	2000 (900)	4.2 (2.0)	SKT63B-12	1" (Bushed to 3/4)
8 (203)	2 (50)	2 1/4 (83)	1500 (675)	3.0 (1.4)	SKT82B-08	20mm (Bushed to 1/2)
	2 1/2 (60)	3 1/4 (83)	2000 (900)	4.9 (2.2)	SKT825B-12	1" (Bushed to 3/4)
	3 (76)	3 1/4 (83)	2500 (1125)	5.2 (2.4)	SKT83B-12	1" (Bushed to 3/4)
10 (254)	2 1/2 (60)	2 3/4 (70)	2000 (900)	6.3 (2.9)	SKT1025B-12	1" (Bushed to 3/4)
	3 (76)	3 1/4 (83)	3000 (1350)	6.8 (3.1)	SKT103B-12	1" (Bushed to 3/4)
12	3 (76)	3 1/4 (83)	3400 (1545)	8.0 (3.6)	SKT123B-12	1" (Bushed to 3/4)

POLYURETHANE /IRON CORE (PI)

Capacities to 9,000 lbs.

Standard Features

- **Composition** - Cast Iron Core with a chemically bonded polyurethane tread
- **Zerk Fitting In Hub** - (5" Dia. up)
- **Tread Hardness** - 90 to 95 dur. shore A
- **Nylon Sealed Washers** - On all 1 1/2" and 2" wide roller bearing wheels

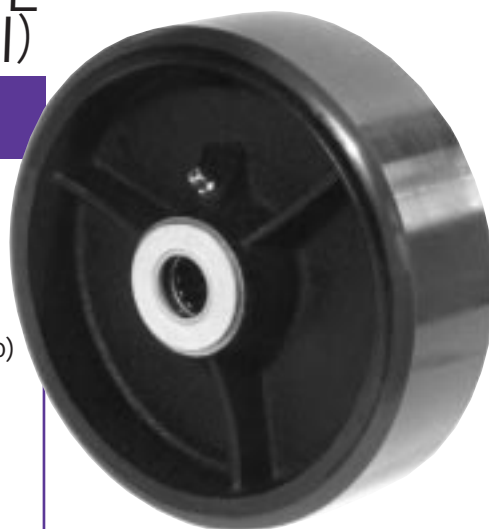

PI62R-12

APPLICATIONS:

General warehouse where high capacity and floor protection are required.

3/8" and 1/2" nominal tread thicknesses allow for low starting and rolling resistance.

Optional Features

- **Roller Bearing Seals** - (Suffix -SW)
- **Tapered Bearing Seals** - Consult factory
- **Special Bore Sizes, Keyways, Set Screws** - Consult factory
- **Low Durometer Tread** - Consult factory

Dia. Inches (mm)	Face Inches (mm)	Hub Length Inches (mm)	Load Capacity lbs. (KGS)	Wt. lbs. (KGS)	Plain Bore or Bore Less Roller Bearing		Roller Bearing		Tapered Roller Bearing	
					Part No.	Sizes	Part No.	Sizes	Part No.	Sizes
3 1/4 (83)	1 1/2 (38)	1 5/8 (41)	450 (203)	1.5 (0.7)	PI31-19	1 3/16	PI31R-12	1/2, 5/8, 3/4	—	—
	2 (50)	2 3/16 (56)	550 (247)	2.5 (1.0)	PI32-19	1 3/16	PI32R-12	1/2, 5/8, 3/4	—	—
4 (102)	1 1/2 (38)	1 5/8 (41)	675 (304)	2.0 (0.9)	PI41-19	1 3/16	PI41R-12	1/2, 5/8, 3/4	—	—
	2 (50)	2 3/16 (56)	750 (338)	3.0 (1.4)	PI42-19	1 3/16	PI42R-12	1/2, 5/8, 3/4	—	—
	3 1/4 (83)	3 1/4 (83)	1275 (574)	5.0 (2.3)	PI43-31	1 15/16	PI43R-16	3/4, 1, 1 1/4	—	—
5 (127)	1 1/2 (38)	1 5/8 (41)	700 (315)	2.5 (1.0)	PI51-19	1 3/16	PI51R-12	1/2, 5/8, 3/4	—	—
	2 (50)	2 3/16 (56)	1050 (473)	3.0 (1.4)	PI52-19	1 3/16	PI52R-12	1/2, 5/8, 3/4	—	—
	3 (76)	3 1/4 (83)	1550 (698)	7.0 (3.0)	PI53-31	1 15/16	PI53R-16	3/4, 1, 1 1/4	PI53T-16	3/4, 1
6 (152)	1 1/2 (38)	1 5/8 (41)	850 (383)	4.0 (1.8)	PI61-19	1 3/16	PI61R-12	1/2, 5/8, 3/4	—	—
	2 (50)	2 3/16 (56)	1200 (540)	4.5 (2.0)	PI62-19	1 3/16	PI62R-12	1/2, 5/8, 3/4	PI62T-12	3/4
	2 1/2 (63)	2 3/4 (70)	1625 (732)	6.5 (2.9)	PIS625-31	1 15/16	PIS625R-16	3/4, 1, 1 1/2	PIS625T-16	3/4, 1
	2 1/2 (63)	3 1/4 (83)	1625 (732)	7.0 (3.0)	PI625-31	1 15/16	PI625R-16	3/4, 1, 1 1/4	PI625T-16	3/4, 1
8 (203)	3 (76)	3 1/4 (83)	2050 (922)	9.5 (4.3)	PI63-31	1 15/16	PI63R-16	1, 1 1/4	PI63T-16	3/4, 1
	2 (50)	2 3/16 (56)	1500 (675)	7.0 (3.0)	PI82-19	1 3/16	PI82R-12	1/2, 5/8, 3/4	PI82T-12	3/4
	2 1/2 (63)	2 3/4 (70)	1950 (878)	8.5 (3.8)	PIS825-31	1 15/16	PIS825R-16	3/4, 1, 1 1/2	PIS825T-12	3/4, 1
	2 1/2 (63)	3 1/4 (83)	1950 (878)	9.5 (4.3)	PI825-31	1 15/16	PI825R-16	3/4, 1, 1 1/2	PI825T-16	3/4, 1
	3 (76)	3 1/4 (83)	2500 (1125)	12.5 (5.6)	PI83-31	1 15/16	PI83R-16	1, 1 1/4	PI83T-16	3/4, 1
9 (229)	4 (102)	4 1/4 (108)	3800 (1710)	16 (7.2)	PI84-31	1 15/16	PI84R-20	1, 1 1/4	PI84T-16	3/4, 1
	5 (133)	5 1/4 (133)	4300 (1935)	30 (13.5)	PI95-39	2 7/16	PI95R-20	1, 1 1/4	PI95T-20	1, 1 1/4
10 (254)	2 1/2 (63)	2 3/4 (70)	2500 (1125)	13 (5.9)	PIS1025-31	1 15/16	PIS1025R-16	3/4, 1, 1 1/4	PIS1025T-16	3/4, 1
	2 1/2 (63)	3 1/4 (83)	2500 (1125)	14 (6.3)	PI1025-31	1 15/16	PI1025R-16	3/4, 1, 1 1/4	PI1025T-16	3/4, 1
	3 (76)	3 1/4 (83)	3000 (1350)	16 (7.2)	PI103-31	1 15/16	PI103R-16	1, 1 1/4	PI103T-16	3/4
	4 (102)	4 1/4 (108)	4200 (1890)	23 (10.4)	PI104-39	2 7/16	PI104R-20	1, 1 1/4	PI104T-20	1, 1 1/4
	5 (133)	5 1/4 (133)	5000 (2250)	33 (15)	PI105-39	2 7/16	PI105R-20	1, 1 1/4, 1 1/2	PI105T-20	1, 1 1/4
12 (305)	2 1/2 (63)	2 3/4 (70)	2800 (1260)	19.5 (8.8)	PIS1225-31	1 15/16	PIS1225R-16	3/4, 1, 1 1/4	PIS1225T-16	3/4, 1
	2 1/2 (63)	3 1/4 (83)	2800 (1260)	19.5 (8.8)	PI1225-31	1 15/16	PI1225R-16	3/4, 1, 1 1/4	PI1225T-16	3/4, 1
	3 (76)	3 1/4 (83)	3850 (1733)	21.5 (9.7)	PI123-31	1 15/16	PI123R-16	1, 1 1/4, 1 1/2	PI123T-16	3/4, 1
	3 1/2 (89)	4 1/4 (108)	4200 (1890)	27 (12)	PI1235-39	2 7/16	PI1235R-20	1, 1 1/4, 1 1/2	PI1235T-16	1, 1 1/4
	4 (102)	4 1/4 (108)	4800 (2160)	30 (13.5)	PI124-39	2 7/16	PI124R-20	1, 1 1/4, 1 1/2	PI124T-20	1, 1 1/4

Dia. Inches (mm)	Face Inches (mm)	Hub Length Inches (mm)	Load Capacity lbs. (KGS)	Wt. lbs. (KGS)	Plain Bore or Bore Less Roller Bearing		Roller Bearing		Tapered Roller Bearing	
					Part No.	Sizes	Part No.	Sizes	Part No.	Sizes
14 (356)	3 (76)	3 1/4 (83)	3650 (1643)	34 (15)	PI143-31	1 15/16	PI143R-20	1, 1 1/4	PI143T-20	1, 1 1/4
16 (406)	3 (76)	3 1/4 (83)	4400 (1980)	32 (14.5)	PI163-31	1 15/16	PI163R-20	1, 1 1/4	PI163T-20	1, 1 1/4
	4 (102)	4 1/4 (108)	6000 (2700)	40 (18)	PI164-39	2 7/16	PI164R-24	1, 1 1/4, 1 1/2	PI164T-20	1, 1 1/4
18 (457)	5 (133)	5 1/4 (133)	7700 (3465)	72 (32)	PI165-39	2 7/16	PI165R-24	1 1/4, 1 1/2	PI165T-20	1 1/4, 1 1/2
	5 (133)	5 1/4 (133)	8500 (3825)	90 (40.5)	PI185-39	2 7/16	PI185R-24	1 1/4, 1 1/2	PI185T-24	1 1/4, 1 1/2
20 (508)	5 (133)	5 1/4 (133)	9000 (4050)	100 (45)	PI205-39	2 7/16	PI205R-24	1 1/4, 1 1/2	PI205T-24	1 1/2

Note: Standard bearing size is called out in last two digits of part number in sixteenths (ie.PI62R -12= 3/4" bearing, PI62R-10 = 5/8" bearing). For smaller bore refer to spanner bushings in component parts selection (page 102).

POLYURETHANE /SEVERE DUTY (PS)

Capacities to 4,800 lbs.

Standard Features

- **Composition** - SAE-1030 Close grained grey iron core
- **Full 1" Polyurethane Tread On All Tapered Bearing Wheels**
- **Heavy Automotive Casting**
- **Tread Hardness** - 90 to 95 dur. shore A
- **Temperature Range Of** -30° to 140°F

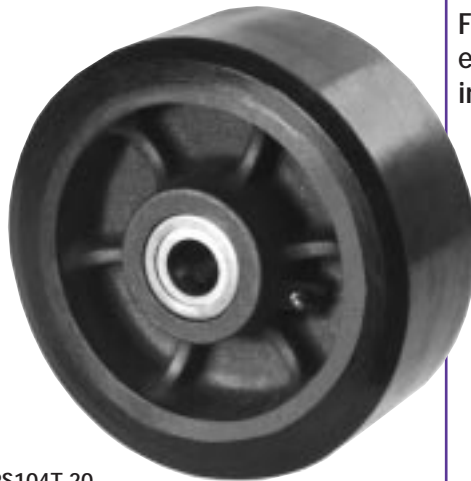

PS104T-20

Optional Features

- **Low Durometer Tread** - 80 shore A (consult factory)
- **Roller Bearing Seals** - (Suffix -SW)

APPLICATIONS:

From general warehouse duty to extreme use applications such as in line tow systems and power drawn trailers.

These quality wheels offer 5-10 times the normal life of rubber. Highest capacities available in a floor protective wheel.



PS82R-12

Dia. Inches (mm)	Face Inches (mm)	Hub Length Inches (mm)	Load Capacity lbs. (KGS)	Wt. lbs. (KGS)	Plain Bore or Bore Less Roller Bearing		Roller Bearing		Tapered Roller Bearing	
					Part No.	Sizes	Part No.	Sizes	Part No.	Sizes
4 (102)	2 (50)	2 1/4 (57)	580 (261)	2.7 (1.2)	PS42-19	1 3/16	PS42R-12	3/4	—	—
5 (127)	2 (50)	2 1/4 (57)	700 (315)	3 (1.4)	PS52-19	1 3/16	PS52R-12	3/4	—	—
6 (152)	2 (50)	2 1/4 (57)	1000 (450)	5 (2.3)	PS62-19	1 3/16	PS62R-12	3/4	—	—
	2 1/2 (64)	2 5/8 (66)	1650 (742)	9 (4.0)	PS625-25	1 9/16	PS625R-16	1	PS625T-12	3/4
8 (203)	3 (76)	3 1/4 (83)	2000 (900)	10 (4.5)	PS63-25	1 9/16	PS63R-16	1	PS63T-12	3/4
	2 (50)	2 1/4 (57)	1350 (608)	10 (4.5)	PS82-19	1 3/16	PS82R-12	3/4	PS82T-12	3/4
	2 1/2 (64)	2 3/4 (70)	2000 (900)	12 (5.4)	PS825-25	1 9/16	PS825R-16	1	PS825T-12	3/4
10 (254)	3 (76)	3 1/4 (83)	2500 (1125)	13 (5.9)	PS83-29	1 13/16	PS83R-16	1	PS83T-12	3/4, 1, 1 1/4
	4 (102)	4 1/2 (114)	4200 (1890)	27 (12)	—	—	—	—	PS104T-20	1 1/4
	2 1/2 (64)	2 3/4 (70)	2000 (900)	18 (8.1)	PS1025-25	1 9/16	PS1025R-16	1	PS1025T-12	3/4
12 (305)	3 (76)	3 1/4 (83)	2600 (1170)	22 (10)	PS103-29	1 13/16	PS103R-16	1	PS103T-12	3/4, 1 1/4
	4 (102)	4 1/2 (114)	4800 (2160)	34 (15)	—	—	—	—	PS123T-12	3/4, 1 1/4
									PS124T-20	1 1/4

Note: Standard bearing size is called out in last two digits of part number in sixteenths (ie.PS62R-12 = 3/4" bearing, PS42R-10 = 5/8" bearing). For smaller bore refer to spanner bushings in component parts selection (page 102).

POLYURETHANE ON POLYOLEFIN (PP)

Capacities to 1,000 lbs.

Standard Features

- **Composition** - Polyurethane tread mechanically and chemically bonded to a polyolefin core
- **Resists Chemicals, Caustics, Acids, And Oils**
- **Quiet Rolling Yet Good Load Capacity**
- **Temperature Range Of -40° to 180°F**
- **Nylon Sealed Washers** - On all roller bearing wheels

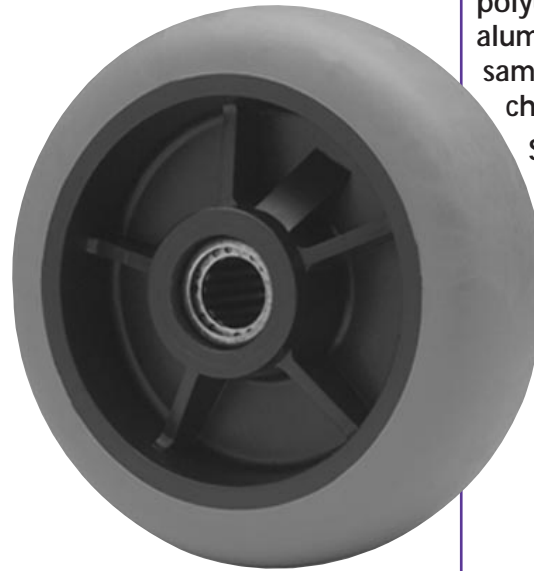

PP62R-12

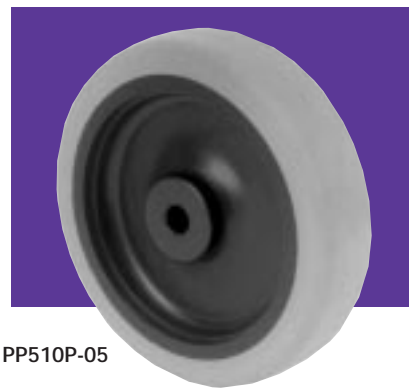

PP510P-05

APPLICATIONS:
A lower cost alternative to polyurethane on steel or aluminum cores yet offers the same long wearing tread characteristics.

Should not be used where possibility for shock or high impact exists. Well suited for wet environments (when supplied with delrin bearings).



PP5B-06

Dia. Inches (mm)	Face Inches (mm)	Hub Length Inches (mm)	Load Capacity lbs (KGS)	Wt. lbs. (KGS)	Ball Bearing		Roller Bearing		Delrin Bearing	
					Part No.	Sizes	Part No.	Sizes	Part No.	Sizes
2 1/2 (60)	13/16 (21)	1 1/64 (26)	140 (63)	.25 (.10)	—	—	—	—	PP2510P-04	1/4
	1 3/8 (35)	1 9/16 (40)	180 (81)	.25 (.10)	PP25B-06	5/16, 3/8, 1/2	—	—	PP25D-06	3/8, 1/2
3 (76)	13/16 (21)	1 5/32 (29)	140 (63)	.2 (.20)	—	—	—	—	PP310P-04	1/4
	1 3/8 (35)	1 9/16 (40)	200 (90)	.5 (.20)	PP3B-06	3/8, 1/2	—	—	PP3D-06	3/8, 1/2
3 1/2 (89)	1 3/8 (35)	1 9/16 (40)	225 (101)	.3 (.14)	PP35B-06	3/8, 1/2	—	—	PP35D-06	3/8, 1/2
4 (102)	15/16 (24)	1 5/32 (29)	145 (65)	.25 (.10)	—	—	—	—	PP410P-05	5/16
	1 3/8 (35)	1 9/16 (40)	250 (112)	.3 (.14)	PP4B-06	3/8, 1/2	—	—	PP4D-06	3/8, 1/2
	2 (50)	2 3/16 (56)	600 (270)	1.2 (.54)	—	—	PP42R-12	1/2, 5/8, 3/4	PP42D-12	1/2, 5/8, 3/4
5 (127)	15/16 (24)	1 5/32 (29)	150 (67)	.3 (.30)	—	—	—	—	PP510P-05	5/16
	1 3/8 (35)	1 9/16 (40)	400 (180)	1.0 (.45)	PP5B-06	—	—	1	PP5D-06	3/8, 1/2
	2 (50)	2 3/16 (56)	750 (338)	1.6 (.72)	—	—	PP52R-12	1/2, 5/8, 3/4	PP52D-12	1/2, 5/8, 3/4
6 (152)	1 3/8 (35)	1 9/16 (40)	290 (130)	1.2 (.54)	PP6B-06	3/8, 1/2	—	—	PP6D-06	3/8, 1/2
	2 (50)	2 3/16 (56)	900 (405)	1.7 (.76)	—	—	PP62R-12	1/2, 5/8, 3/4	PP62D-12	1/2, 5/8, 3/4
8 (203)	2 (50)	2 3/16 (56)	1000 (450)	2.5 (1.1)	—	—	PP82R-12	1/2, 5/8, 3/4	PP82D-12	1/2, 5/8, 3/4

Note: 3/16 " and 15/16 " wide wheels are plain bore.

Note: Standard bearing size is called out in last two digits of part number in sixteenths (ie. PP62R-12 = 3/4" bearing, PP62R-10 = 5/8" bearing). For smaller bore refer to spanner bushings in component parts selection (page 102).