

SERIES KP1 KINGPIN-FREE MED HEAVY DUTY

Capacities to 1,500 lbs.

Standard Features

- **Top Plate** - High strength alloy steel 1-piece forging
- **Yoke Base** - Precision machined and hardened for extended life

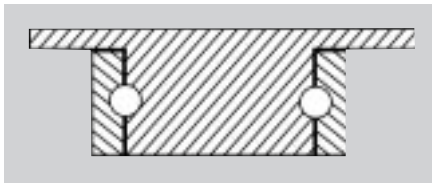

- **Swivel Assembly** - $\frac{3}{8}$ " ball bearing mounted in a 2" precision machined raceway hardened to 50 Rockwell C
- **Legs** - $\frac{1}{4}$ " steel formed to increase strength and welded to yoke base
- **Axle** - $\frac{1}{2}$ " diameter
- **Wheel bearings** - straight roller bearing standard
- **Finish** Corrosion Resistant Zinc

Optional Features

- **Wheel Brake Cam Style** (Suffix -WB)
- **4-Position Swivel Lock** (Suffix -SL)
- **Sealed Swivel Assembly** (Suffix -SS)
- **Powder Coating** (Call Factory)
- **Thread Guards** (Suffix -TG)
- **Delrin Bearing** (Change R to D)
Example: SKP162D -PH



APPLICATIONS:

Kingpin-Free Casters have rugged one-piece forged steel top plate which eliminates the two-piece weldment that can separate causing failure of the competitive models. This caster was designed for shock loading applications and any area where a rugged, durable caster is needed.



Standard Top Plate #1

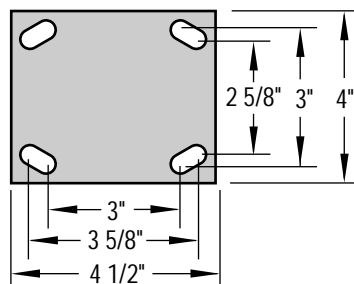

Optional Top Plate #3

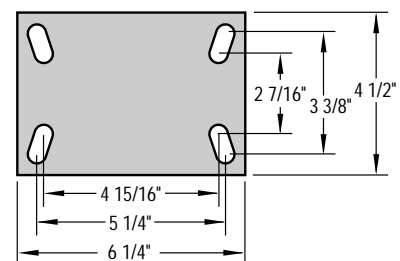

Wheel Specifications					Caster Specifications						Part Number		
Dia. "A" Inches (mm)	Tread Inches (mm)	Wheel Composition	Ref. to Page	Bearing Type	Axle Dia. Inches (mm)	Load Capacity lbs. (KGS)	Overall Height "B" Inches (mm)	Swivel Radius Inches (mm)	Attach. Bolt Inches (mm)	Approx. Shipping Wt.		Swivel Caster	Rigid Caster
										Swivel lbs. (KGS)	Rigid lbs. (KGS)		
4 (102)	2 (50)	Cast Iron	86	Roller	1/2 (13)	800 (360)	5 5/8 (143)	3 11/16 (94)	1/2 (13)	8.5 (3.8)	7.5 (3.4)	SKP142R-SS	RKP142R-SS
		Phenolic	82	Roller		800 (360)				6.0 (2.7)	5.0 (2.5)	SKP142R-PH	RKP142R-PH
		Mold-on Rubber	74	Roller		350 (157)				8.5 (3.8)	7.5 (3.4)	SKP142R-MR	RKP142R-MR
		Polyurethane (Cast Iron Core)	78	Roller		700 (315)				8.5 (3.8)	7.5 (3.4)	SKP142R-PI	RKP142R-PI
		Polyurethane (Aluminum Core)	75	Roller		700 (315)				7.0 (3.2)	6.0 (2.7)	SKP142R-PA	RKP142R-PA
		Solid Urethane	77	Roller		700 (315)				6.5 (3.0)	5.5 (2.5)	SKP142R-KT	RKP142R-KT
		Polyurethane (Polyolefin Core)	80	Roller		700 (315)				6.0 (2.7)	5.0 (2.5)	SKP142R-PP	RKP142R-PP
		Polyolefin	81	Roller		450 (202)				6.0 (2.7)	5.0 (2.5)	SKP142R-PB	RKP142R-PB
	1 1/2 (38)	Forged Steel	88	Roller		1400 (630)				8.0 (3.6)	7.0 (3.2)	SKP141R-FS	RKP141R-FS
5 (127)	2 (50)	Cast Iron	86	Roller	1/2 (13)	900 (405)	6 1/2 (165)	4 3/16 (106)	1/2 (13)	8.8 (4.0)	8.3 (3.7)	SKP152R-SS	RKP152R-SS
		Phenolic	82	Roller		900 (405)				6.5 (3.0)	6.0 (2.7)	SKP152R-PH	RKP152R-PH
		Mold-on Rubber (Cast Iron Core)	74	Roller		400 (180)				8.8 (4.0)	8.3 (3.7)	SKP152R-MR	RKP152R-MR
		Polyurethane (Cast Iron Core)	78	Roller		900 (405)				8.8 (4.0)	8.3 (3.7)	SKP152R-PI	RKP152R-PI
		Polyurethane (Aluminum Core)	75	Roller		900 (405)				7.0 (3.2)	6.5 (3.0)	SKP152R-PA	RKP152R-PA
		Solid Urethane	77	Roller		900 (405)				7.0 (3.2)	6.5 (3.0)	SKP152R-KT	RKP152R-KT
		Polyurethane (Polyolefin Core)	80	Roller		750 (340)				6.5 (3.0)	6.0 (2.7)	SKP152R-PP	RKP152R-PP
		Polyolefin	81	Roller		650 (300)				6.0 (2.7)	5.5 (2.5)	SKP152R-PB	RKP152R-PB
	Forged Steel	88	Roller	1100 (500)		8.8 (4.0)				8.3 (3.7)	SKP152R-FS	RKP152R-FS	
6 (152)	2 (50)	Cast Iron	86	Roller	1/2 (13)	1000 (850)	7 1/2 (191)	4 5/8 (118)	1/2 (13)	9.0 (4.1)	8.5 (3.6)	SKP162R-SS	RKP162R-SS
		Phenolic	82	Roller		1000 (450)				7.0 (3.2)	6.0 (2.7)	SKP162R-PH	RKP162R-PH
		Mold-on Rubber (Cast Iron Core)	74	Roller		410 (184)				9.0 (4.1)	8.0 (3.6)	SKP162R-MR	RKP162R-MR
		Polyurethane (Cast Iron Core)	78	Roller		1000 (450)				9.0 (4.1)	8.0 (3.6)	SKP162R-PI	RKP162R-PI
		Polyurethane (Aluminum Core)	75	Roller		1000 (450)				7.5 (3.4)	6.5 (2.9)	SKP162R-PA	RKP162R-PA
		Solid Urethane	77	Roller		1000 (450)				7.5 (3.4)	6.5 (2.9)	SKP162R-KT	RKP162R-KT
		Polyurethane (Polyolefin Core)	80	Roller		700 (315)				7.0 (3.2)	6.0 (2.7)	SKP162R-PP	RKP162R-PP
		Polyolefin	81	Roller		650 (300)				6.5 (2.9)	5.5 (2.5)	SKP162R-PB	RKP162R-PB
	Forged Steel	88	Roller	1500 (675)		9.3 (4.2)				8.3 (3.7)	SKP162R-FS	RKP162R-FS	
8 (203)	2 (50)	Cast Iron	86	Roller	1/2 (13)	1000 (450)	10 1/8 (257)	5 3/4 (146)	1/2 (13)	12.0 (5.4)	11.0 (5.0)	SKP182R-SS	RKP182R-SS
		Phenolic	82	Roller		1000 (450)				8.5 (3.8)	7.5 (3.4)	SKP182R-PH	RKP182R-PH
		Mold-on Rubber (Cast Iron Core)	74	Roller		500 (225)				10.5 (4.5)	9.0 (4.1)	SKP182R-MR	RKP182R-MR
		Polyurethane (Cast Iron Core)	78	Roller		1500 (450)				10.5 (4.5)	9.5 (4.3)	SKP182R-PI	RKP182R-PI
		Polyurethane (Aluminum Core)	75	Roller		1000 (450)				8.0 (3.6)	7.0 (3.2)	SKP182R-PA	RKP182R-PA
		Solid Urethane	77	Roller		1000 (450)				8.5 (3.8)	7.5 (3.4)	SKP182R-KT	RKP182R-KT
		Polyurethane (Polyolefin Core)	80	Roller		900 (405)				7.5 (3.4)	6.5 (2.9)	SKP182R-PP	RKP182R-PP
		Polyolefin	81	Roller		700 (315)				6.5 (2.9)	5.5 (2.5)	SKP182R-PB	RKP182R-PB

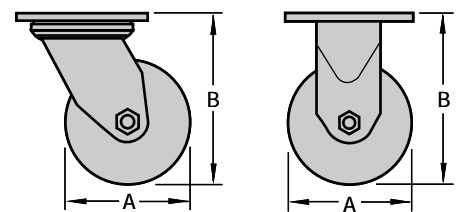

SERIES KP7 KINGPIN-FREE HEAVY DUTY

Capacities to 5,500 lbs.

Standard Features

- **Top Plate/Yoke Base** - AISI-1045 Steel one piece forging precision machined and hardened. $\frac{3}{8}$ " Top Plate Thickness
- **Yoke Base** - is pre-notched for field installable swivel lock

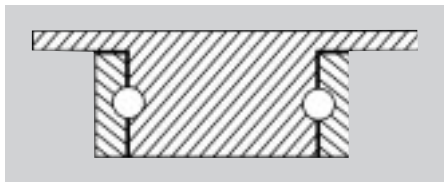

- **Swivel Assembly** - $\frac{1}{2}$ " ball bearing mounted in a 3" precision machined raceway
- **Legs** - $\frac{3}{8}$ " steel welded to base inside and out
- **Axle** - $\frac{3}{4}$ " diameter

Optional Features

- **Bolt On Swivel Lock** (Suffix-SL)
Can be ordered separately (Part No. KPL-SL)
- **Wheel Brake Options**
Face Contact Brake (Suffix-FCB)
Thumb Screw Brake (Suffix-WB)

Standard Top Plate

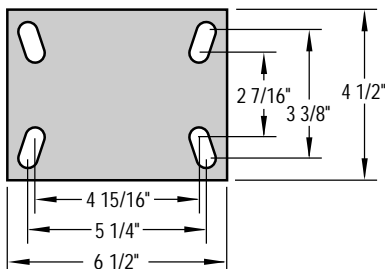

APPLICATIONS:

Constructed to withstand shock loads, This uniquely manufactured product is suitable for all heavy duty requirements. Kingpin-Free swivel assembly is designed for maintenance free service.

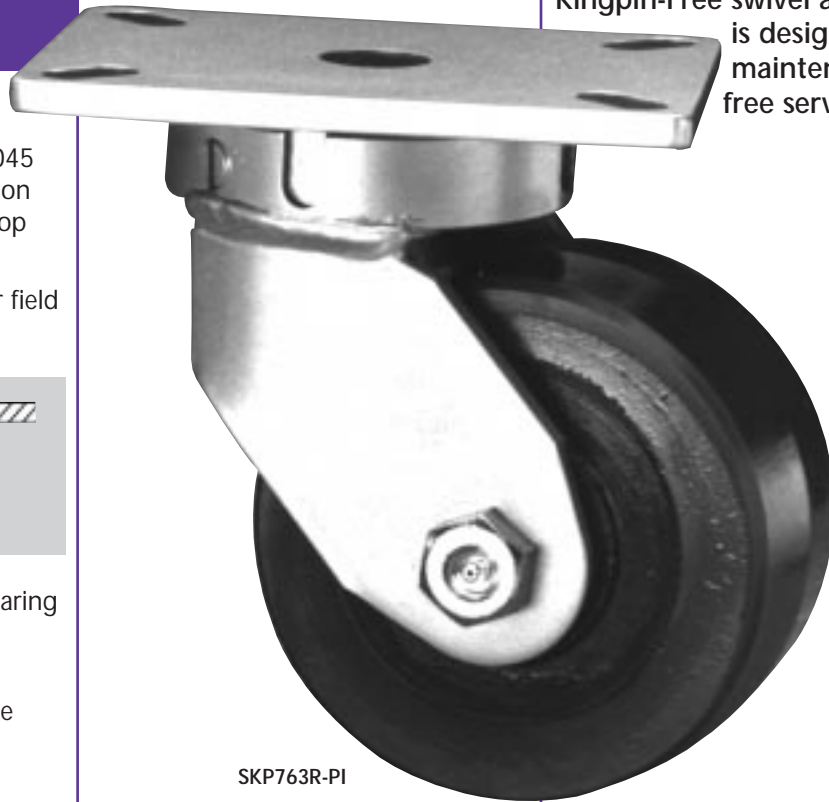

SKP763R-PI



RKP763R-PI

Wheel Specifications					Caster Specifications						Part Number		
Dia. "A" Inches (mm)	Tread Inches (mm)	Wheel Composition	Ref. to Page	Bearing Type	Axle Dia. Inches (mm)	Load Capacity lbs. (KGS)	Overall Height "B" Inches (mm)	Swivel Radius Inches (mm)	Attach. Bolt Inches (mm)	Approx. Shipping Wt.		Swivel Caster	Rigid Caster
										Swivel lbs. (KGS)	Rigid lbs. (KGS)		
6 (152)	3 (76)	Cast Iron	86	Roller	3/4 (19)	2000 (900)	7 1/2 (190)	4 1/2 (114)	1/2 (13)	23.0 (10.3)	10.5 (4.7)	SKP763R-SS	RKP763R-SS
		Phenolic	82	Roller		2000 (900)				15.0 (6.8)	6.75 (3.0)	SKP763R-PH	RKP763R-PH
		Mold-on Rubber (Cast Iron Core)	74	Roller		540 (240)				20.0 (9.0)	9.0 (4.0)	SKP763R-MR	RKP763R-MR
		Polyurethane (Iron Core)	78	Roller		2000 (900)				21.0 (9.5)	9.5 (4.3)	SKP763R-PI	RKP763R-PI
		Severe Duty Polyurethane	79	Tapered Roller		2500 (1100)				24.0 (10.5)	13.0 (6.0)	SKP763T-PA	RKP763T-PS
	2 1/2 (60)	Solid Urethane	77	Prec. Ball		2000 (900)				15.0 (6.8)	10.0 (4.5)	SKP7625B-SKT	RKP7625B-SKT
	Forged Steel	88	Roller	5000 (2250)		21.0 (9.5)				9.5 (4.3)	SKP7625R-FS	RKP7625R-FS	
8 (203)	3 (76)	Cast Iron	86	Roller	1/2 (13)	2500 (1100)	10 1/8 (257)	6 1/4 (159)	1/2 (13)	24.0 (10.5)	11.5 (5.0)	SKP783R-SS	RKP783R-SS
		Phenolic		Roller		2500 (1100)				19.0 (6.8)	8.5 (3.0)	SKP783R-PH	RKP783R-PH
		Mold-on Rubber (Cast Iron Core)	82	Roller		670 (240)				21.0 (9.0)	9.5 (4.0)	SKP783R-MR	RKP783R-MR
		Polyurethane (Iron Core)	74	Roller		2500 (900)				23.0 (9.5)	10.5 (4.3)	SKP783R-PI	RKP783R-PI
		Severe Duty Polyurethane	79	Tapered Roller		2500 (1100)				25.0 (10.5)	11.5 (6.0)	SKP783T-PS	RKP783T-PS
	2 1/2 (60)	Solid Urethane	77	Prec. Ball		2000 (900)				19.0 (6.8)	8.5 (4.5)	SKP7825B-SKT	RKP7825B-SKT
	Forged Steel	88	Roller	4000 (2250)		23.0 (9.5)				10.5 (4.3)	SKP7825R-FS	RKP7825R-FS	
10 (254)	3 (76)	Cast Iron	86	Roller	1/2 (13)	2500 (1100)	11 1/2 (292)	7 1/2 (190)	3/8 (10)	27.0 (12.2)	12.0 (5.4)	SKP7103R-SS	RKP7103R-SS
		Phenolic	82	Roller		2500 (1100)				21.0 (9.5)	9.5 (4.3)	SKP7103R-PH	RKP7103R-PH
		Mold-on Rubber (Cast Iron Core)	74	Roller		1000 (450)				23.0 (10.4)	10.5 (4.7)	SKP7103R-MR	RKP7103R-MR
		Polyurethane (Iron Core)	78	Roller		2500 (1100)				28.0 (12.6)	12.5 (5.6)	SKP7103R-PI	RKP7103R-PI
		Severe Duty Polyurethane	79	Tapered Roller		3000 (1350)				30.0 (13.5)	14.5 (6.5)	SKP7103T-PS	RKP7103T-PS
		Solid Urethane	77	Prec. Ball		2500 (1100)				21.0 (9.5)	9.5 (4.3)	SKP7103B-SKT	RKP7103B-SKT
		Forged Steel	88	Roller		4600 (2000)				28.0 (12.6)	12.5 (5.6)	SKP7103R-FS	RKP7103R-FS
12 (305)	3 (76)	Cast Iron	86	Roller	1/2 (13)	2500 (1100)	13 1/2 (343)	9 (228)	1/2 (13)	32.0 (14.4)	14.5 (6.5)	SKP7123R-SS	RKP7123R-SS
		Phenolic	82	Roller		3500 (1500)				24.0 (10.8)	11.0 (5.0)	SKP7123R-PH	RKP7123R-PH
		Mold-on Rubber (Cast Iron Core)	74	Roller		1140 (500)				30.0 (13.5)	13.5 (6.1)	SKP7123R-MR	RKP7123R-MR
		Polyurethane (Iron Core)	78	Roller		3500 (1500)				35.0 (15.8)	16.0 (7.2)	SKP7123R-PI	RKP7123R-PI
		Severe Duty Polyurethane	79	Tapered Roller		3500 (1500)				37.0 (16.8)	18.0 (8.2)	SKP7123T-PS	RKP7123T-PS
		Solid Urethane	77	Prec. Ball		3000 (1350)				30.0 (13.5)	13.5 (6.1)	SKP7123B-SKT	RKP7123B-SKT
		Forged Steel											

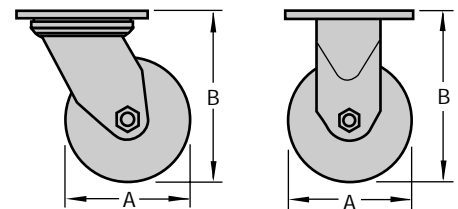

SERIES KP8 KINGPIN-FREE HEAVY DUTY

Capacities to 5,000 lbs.

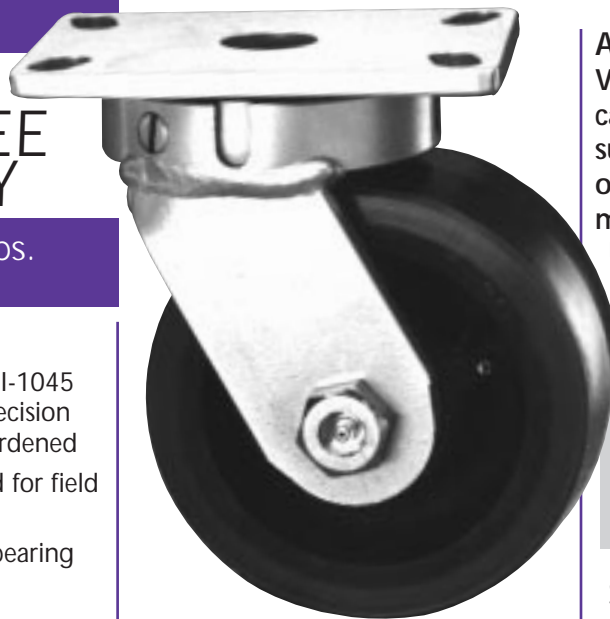

Standard Features

- **Top Plate/Yoke Base** - AISI-1045 Steel one piece forging precision machined and through hardened
- **Yoke Base** - is pre-notched for field installable swivel lock
- **Swivel Section** - 1/2" ball bearing mounted in a 3" precision machined raceway
- **Legs** - 3/8" steel welded to yoke base using 100,000 PSI weld filler, welded inside and out
- **Axle** - 3/4" diameter

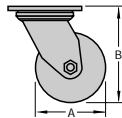

Optional Features

- **Bolt On Swivel Lock** (Suffix -SL)
Can be ordered separately (Part No. KP7-SL)
- **Wheel Brake Options**
Face Contact Brake (Suffix -FCB)
Thumb Screw Brake (Suffix -WB)

APPLICATIONS:

Virtually all equipment where capacities require a caster of superior construction. In plant operations will benefit from low maintenance service for life.

Unlike similar designs, the one-piece top plate/yoke base adds a measure of safety by eliminating a weldment.

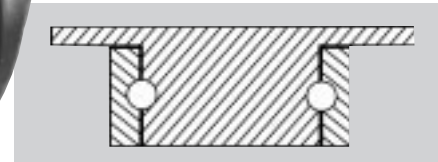

Standard Top Plate

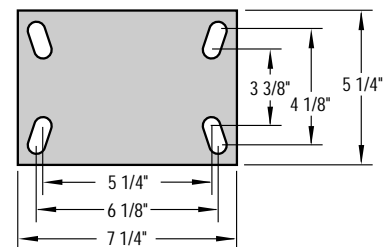

Wheel Specifications					Caster Specifications						Part Number		
Dia. "A" Inches (mm)	Tread Inches (mm)	Wheel Composition	Ref. to Page	Bearing Type	Axle Dia. Inches (mm)	Load Capacity lbs. (KGS)	Overall Height "B" Inches (mm)	Swivel Radius Inches (mm)	Attach. Bolt Inches (mm)	Approx. Shipping Wt.		Swivel Caster	Rigid Caster
										Swivel lbs. (KGS)	Rigid lbs. (KGS)		
6 (152)	3 (76)	Cast Iron	86	Roller	3/4 (19)	2000 (900)	8 (203)	4 1/2 (114)	1/2 (13)	26.0 (11.7)	20.5 (9.0)	SKP863R-SS	RKP863R-SS
		Phenolic	82	Roller		2000 (900)				18.0 (8.1)	12.0 (5.4)	SKP863R-PH	RKP863R-PH
		Mold-on Rubber (Cast Iron Core)	74	Roller		540 (240)				20.0 (9.0)	14.0 (6.3)	SKP863R-MR	RKP863R-MR
		Polyurethane (Iron Core)	78	Roller		2000 (900)				20.0 (9.0)	14.0 (6.3)	SKP863R-PI	RKP863R-PI
	2 1/2 (60)	Severe Duty Polyurethane	79	Tapered Roller		2500 (1100)				22.0 (9.9)	18.0 (7.2)	SKP863T-PS	RKP863T-PS
		Solid Urethane	77	Prec. Ball		2000 (900)				18.0 (8.1)	12.0 (5.4)	SKP8625B-SKT	RKP8625B-SKT
		Forged Steel	88	Roller		5000 (2250)				26.0 (11.7)	20.5 (10.4)	SKP8625R-FS	RKP8625R-FS
		8 (203)	3 (76)	Cast Iron		86				Roller	3/4 (19)	2500 (1100)	10 1/2 (267)
Phenolic	82			Roller	2500 (1100)	20.0 (9.0)	17.0 (6.9)	SKP883R-PH	RKP883R-PH				
Mold-on Rubber (Cast Iron Core)	74			Roller	670 (300)	22.0 (9.9)	19.0 (8.6)	SKP883R-MR	RKP883R-MR				
Polyurethane (Iron Core)	78			Roller	2500 (1100)	22.0 (9.9)	19.5 (8.6)	SKP883R-PI	RKP883R-PI				
2 1/2 (60)	Severe Duty Polyurethane		79	Tapered Roller	2500 (1100)	26.0 (11.7)	23.0 (10.4)	SKP883T-PS	RKP883T-PS				
	Solid Urethane		77	Prec. Ball	2000 (900)	20.0 (9.0)	17.5 (6.9)	SKP8825B-SKT	RKP8825B-SKT				
	Forged Steel		88	Roller	4000 (1800)	32.0 (14.4)	29.5 (13.0)	SKP8825R-FS	RKP8825R-FS				
	10 (254)		3 (76)	Cast Iron	86	Roller	3/4 (19)	2500 (1100)	12 1/2 (317)	7 1/2 (190)		1/2 (13)	
Phenolic		82		Roller	2500 (1100)	28.0 (12.6)		22.5 (9.9)			SKP8103R-PH		RKP8103R-PH
Mold-on Rubber (Cast Iron Core)		74		Roller	1000 (900)	31.0 (14.0)		25.0 (11.3)			SKP8103R-MR		RKP8103R-MR
Polyurethane (Iron Core)		78		Roller	2500 (1100)	36.0 (16.2)		30.0 (14.0)			SKP8103R-PI		RKP8103R-PI
2 1/2 (60)		Severe Duty Polyurethane	79	Tapered Roller	3000 (1350)	37.0 (16.7)		31.5 (14.8)			SKP8103T-PS		RKP8103T-PS
		Solid Urethane	77	Prec. Ball	2500 (1100)	28.0 (12.6)		22.0 (9.9)			SKP8103B-SKT		RKP8103B-SKT
		Forged Steel	88	Roller	4600 (2000)	38.0 (17.1)		31.0 (14.0)			SKP8103R-FS		RKP8103R-FS
		12 (305)	3 (76)	Cast Iron	86	Roller		3/4 (19)			2500 (1100)		15 1/2 (394)
Phenolic	82			Roller	3500 (1500)	32.0 (14.4)	28.0 (12.6)		SKP8123R-PH	RKP8123R-PH			
Mold-on Rubber (Cast Iron Core)	74			Roller	1140 (500)	37.0 (16.7)	31.0 (14.0)		SKP8123R-MR	RKP8123R-MR			
Polyurethane (Iron Core)	78			Roller	3500 (1500)	41.0 (18.5)	35.0 (15.8)		SKP8123R-PI	RKP8123R-PI			
Severe Duty Polyurethane	79			Tapered Roller	3500 (1500)	41.0 (18.5)	35.0 (15.8)		SKP8123T-PS	RKP8123T-PS			
Solid Urethane	77			Prec. Ball	3000 (1350)	32.0 (14.4)	28.0 (12.6)		SKP8123B-SKT	RKP8123B-SKT			

SERIES KP11 KINGPIN-FREE HEAVY DUTY

Capacities to 7,700 lbs.

Standard Features

- **Top Plate/Yoke Base** - AISI-1045 Steel one piece forging precision machined and through hardened. 1/2" top plate thickness
- **Yoke Base** - is pre-notched for field installable swivel lock

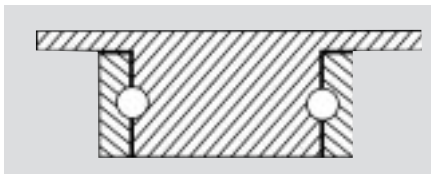

- **Swivel Section** - 3/4" ball bearings mounted in a 4 1/2" diameter precision raceway
- **Legs** - 3/8" formed steel to increase strength and welded to yoke base using 100,000 PSI weld filler, welded inside and out
- **Axle** - 1" diameter

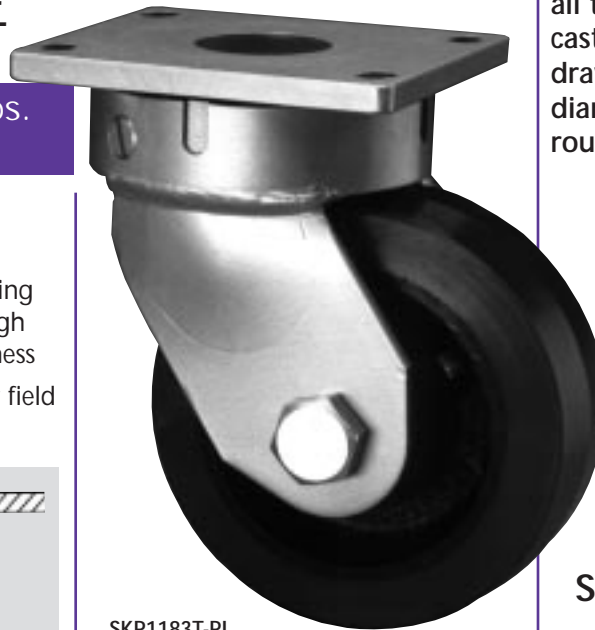

SKP1183T-PI

Optional Features

- **Bolt on Swivel Lock** (Suffix-SL)
- **Wheel Brake options**
Face Contact Brake (suffix-FCB)
Thumb Screw Brake (suffix-WB)

APPLICATIONS:

Used on mobile equipment of all types. Heavier capacity casters are suitable for power drawn applications. Large diameter wheels available for rougher surfaces.



Standard Top Plate

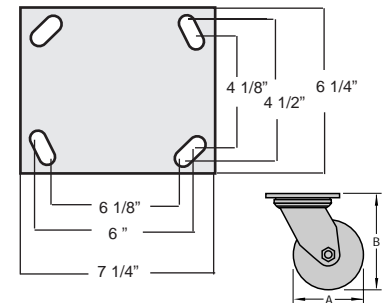

Wheel Specifications					Caster Specifications					Part Number			
Dia. "A" Inches (mm)	Tread Inches (mm)	Wheel Composition	Ref. to Page	Bearing Type	Axle Dia. Inches (mm)	Load Capacity lbs. (KGS)	Overall Height "B" Inches (mm)	Swivel Radius Inches (mm)	Attach. Bolt Inches (mm)	Approx. Shipping Wt.		Swivel Caster	Rigid Caster
										Swivel lbs. (KGS)	Rigid lbs. (KGS)		
6 (152)	2 1/2 (60)	Forged Steel	88	Roller	1 (25)	4000 (1800)	8 1/2 (216)	5 1/2 (140)	1/2 (13)	35 (16)	27 (12)	SKP11625R-FS	RKP11625R-FS
		Cast Iron	86	Roller		2500 (900)				31 (14)	23 (10)	SKP1163R-SS	RKP1163R-SS
	Phenolic	82	Roller	2000 (900)		25 (11)				17 (8)	SKP1163R-PH	RKP1163R-PH	
	Polyurethane (Cast Iron Core)	78	Tapered Roller	2000 (900)		33 (15)				25 (11)	SKP1163T-PI	RKP1163T-PI	
	Forged Steel	88	Tapered Roller	10000 (4500)		36 (17)				28 (13)	SKP1163T-FS	RKP1163T-FS	
8 (203)	2 1/2 (60)	Forged Steel	88	Roller	1 (25)	4000 (1800)	10 1/2 (267)	6 1/2 (165)	1/2 (13)	37 (17)	29 (14)	SKP11825R-FS	RKP11825R-FS
		Cast Iron	86	Roller		2500 (1140)				34 (15)	26 (12)	SKP1183R-SS	RKP1183R-SS
		Phenolic	82	Roller		2500 (1140)				29 (13)	20 (9)	SKP1183R-PH	RKP1183R-PH
		Polyurethane (Cast Iron Core)	78	Tapered Roller		2500 (1140)				36 (16)	27 (12)	SKP1183T-PI	RKP1183T-PI
		Forged Steel	88	Tapered Roller		5500 (2500)				39 (17)	31 (14)	SKP1183T-FS	RKP1183T-FS
	4 (102)	Cast Iron	86	Roller		4000 (1800)				46 (21)	39 (18)	SKP1184R-SS	RKP1184R-SS
		Polyurethane (Cast Iron Core)	78	Tapered Roller		3500 (1590)				45 (20)	38 (17)	SKP1184T-PI	RKP1184T-PI
		Cast Iron	86	Roller		2500 (1140)				45 (20)	37 (16)	SKP11103R-SS	RKP11103R-SS
		Phenolic	82	Roller		2600 (1200)				32 (15)	24 (11)	SKP11103R-PH	RKP11103R-PH
10 (254)	3 (76)	Polyurethane (Cast Iron Core)	78	Tapered Roller	3000 (1360)	48 (22)	40 (18)	SKP11103T-PI	RKP11103T-PI				
		Forged Steel	88	Tapered Roller	6000 (2720)	52 (24)	44 (20)	SKP11103T-FS	RKP11103T-FS				
		Polyurethane (Cast Iron Core)	78	Tapered Roller	4200 (1900)	60 (27)	52 (24)	SKP11104T-PI	RKP11104T-PI				
		Forged Steel	88	Tapered Roller	10000 (4500)	66 (30)	58 (26)	SKP11104T-FS	RKP11104T-FS				
	4 (102)	Phenolic	82	Roller	4000 (1800)	51 (23)	39 (18)	SKP11235R-PH	RKP11235R-PH				
12 (305)	4 (102)	Polyurethane (Cast Iron Core)	78	Tapered Roller	4800 (2200)	70 (32)	59 (27)	SKP1124T-PI	RKP1124T-PI				

SERIES KP12 KINGPIN-FREE HEAVY DUTY

Capacities to 20,000 lbs.



APPLICATIONS:

Equipment requiring high capacity coupled with construction suitable for powered movement. Large diameter wheel selections allow for movement over rough surfaces such as pavement or cement lots.



Standard Features

- **Top Plate/Yoke Base** - AISI 1045 Steel one piece forging precision machined and through hardened. 1/2" top plate thickness
- **Yoke Base** - is pre-notched for field installable swivel lock.



- **Swivel Section** - 3/4" ball bearings mounted in a 7" diameter precision raceway.
- **Legs** - 1/2" formed steel to increase strength and welded to yoke base using 100,000 PSI weld filler, welded inside and out.
- **Axel** - 1 1/4" diameter.

Optional Features

- **Bolt on Swivel Lock (Suffix-SL)**
- **Wheel Brake options**
face contact brake (suffix-FCB)
thumb screw brake (suffix-WB)

Standard Top Plate

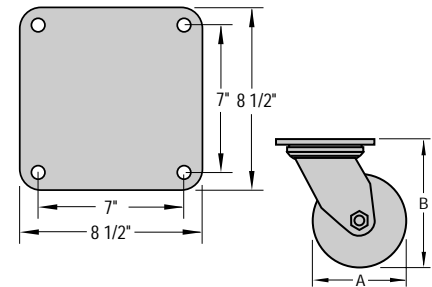

Wheel Specifications						Caster Specifications						Part Number	
Dia. "A" Inches (mm)	Tread Inches (mm)	Wheel Composition	Ref. to Page	Bearing Type	Axle Dia. Inches (mm)	Load Capacity lbs. (KGS)	Overall Height "B" Inches (mm)	Swivel Radius Inches (mm)	Attach. Bolt Inches (mm)	Approx. Shipping Wt.		Swivel Caster	Rigid Caster
										Swivel lbs. (KGS)	Rigid lbs. (KGS)		
8 (203)	4 (102)	Cast Iron	86	Tapered Roller	1 1/4 (32)	6000 (2700)	11 (279)	6 1/4 (159)	5/8 (16)	69 (31)	48 (22)	SKP1284T-SS	RKP1284T-SS
		Forged Steel	88	Tapered Roller		10000 (4500)				73 (33)	52 (24)	SKP1284T-FS	RKP1284T-FS
		Polyurethane (Cast Iron Core)	78	Tapered Roller		3500 (1600)				70 (32)	49 (22)	SKP1284T-PI	RKP1284T-PI
10 (254)	4 (102)	Cast Iron	88	Tapered Roller	1 1/4 (32)	4000 (1800)	13 (330)	7 1/2 (191)	5/8 (16)	76 (35)	59 (29)	SKP12104T-SS	RKP12104T-SS
		Forged Steel	86	Tapered Roller		20000 (9000)				84 (38)	67 (30)	SKP12104T-FS	RKP12104T-FS
		Mold-on Rubber (Cast Iron Core)	74	Tapered Roller		1400 (636)				80 (36)	63 (29)	SKP12104T-MR	RKP12104T-MR
		Polyurethane (Cast Iron Core)	78	Tapered Roller		4200 (1909)				81 (37)	64 (30)	SKP12104T-PI	RKP12104T-PI
	5 (127)	Polyurethane (Cast Iron Core)	78	Tapered Roller	1 1/4 (32)	5000 (2250)	13 (330)	8 (203)	5/8 (16)	88 (40)	71 (32)	SKP12105T-PI	RKP12105T-PI
12 (305)	4 (102)	Mold-on Rubber (Cast Iron Core)	74	Tapered Roller	1 1/4 (32)	1600 (727)	15 1/2 (394)	9 1/4 (235)	5/8 (16)	78 (35)	61 (28)	SKP12124T-MR	RKP12124T-MR
		Polyurethane (Cast Iron Core)	78	Tapered Roller		4800 (2182)				77 (35)	60 (27)	SKP12124T-PI	RKP12124T-PI
	5 (127)	Polyurethane (Cast Iron Core)	78	Tapered Roller	1 1/4 (32)	6000 (2700)				90 (41)	73 (33)	SKP12125T-PI	RKP12125T-PI
	6 (152)	Polyurethane (Cast Iron Core)	78	Tapered Roller	1 1/4 (32)	7500 (3409)				93 (42)	76 (34)	SKP12126T-PI	RKP12126T-PI
16 (406)	4 (102)	Mold-on Rubber (Cast Iron Core)	74	Tapered Roller	1 1/4 (32)	1900 (864)	19 (483)	12 1/2 (318)	5/8 (16)	96 (44)	79 (36)	SKP12164T-MR	RKP12164T-MR
		Polyurethane (Cast Iron Core)	78	Tapered Roller		5970 (2713)				95 (44)	78 (36)	SKP12164T-PI	RKP12164T-PI
	5 (127)	Mold-on Rubber (Cast Iron Core)	74	Tapered Roller	1 1/4 (32)	2570 (1168)				102 (46)	85 (37)	SKP12165T-MR	RKP12165T-MR
	Polyurethane (Cast Iron Core)	78	Tapered Roller	7700 (4000)	101 (46)	84 (39)				SKP12165T-PI	RKP12165T-PI		

SERIES KP13 KINGPIN-FREE DUAL WHEEL

Capacities to 30,000 lbs.

Standard Features

- **Top Plate** - AISI 1045 steel one piece forging precision machined and through hardened, $\frac{3}{4}$ " top plate thickness.
- **Yoke Base** - AISI 1045 steel forging, welded using 100,000 PSI weld filler to $\frac{3}{4}$ " thick adapter plate. Pre-notched for field installable swivel lock.
- **Swivel Assembly** - $\frac{7}{8}$ " ball bearings mounted in a 7" diameter precision raceway.
- **Legs** - $\frac{3}{4}$ " steel welded to Yoke Base, inside and out.
- **Axle** - $1\frac{1}{4}$ " diameter.

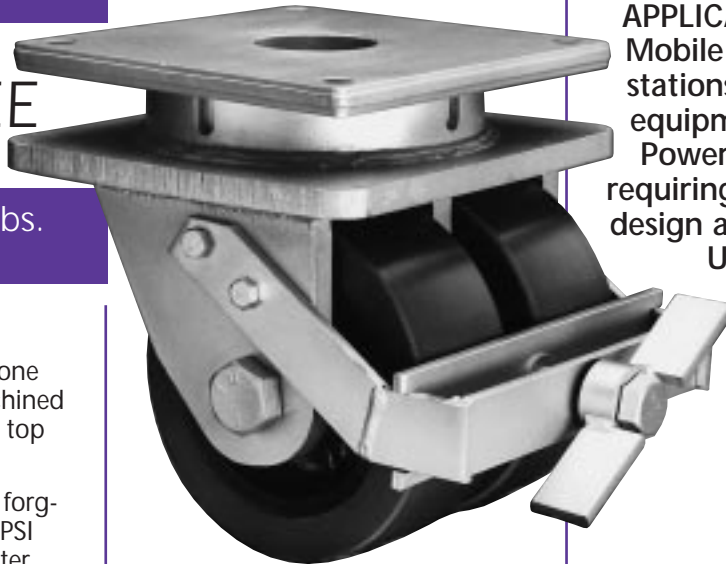
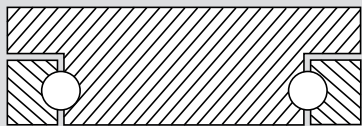

KP13124T-PI-FCB

Optional Features

- **Face Contact Brake** (Suffix -FCB)
- **4-Position Swivel Lock** (Suffix -SL)
- **Special Designs** (Consult Factory)
 - Single wheel
 - Spring loaded shock absorbing

APPLICATIONS:
Mobile platforms, work stations, ground support equipment of all types. Power drawn applications requiring superior capacity, design and construction. Unique swivel assembly suitable for loads up to 30,000 pounds ensures load safety.

Standard Top Plate

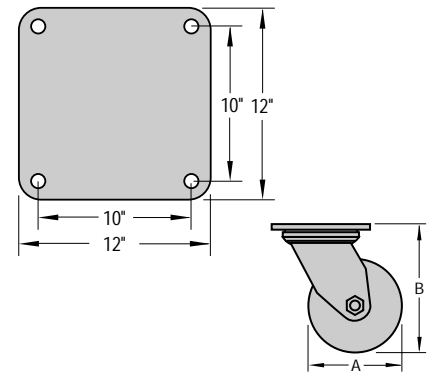

Wheel Specifications						Caster Specifications					Part Number		
Dia. "A" Inches (mm)	Tread Inches (mm)	Wheel Composition	Ref. to Page	Bearing Type	Axle Dia. Inches (mm)	Load Capacity lbs. (KGS)	Overall Height "B" Inches (mm)	Swivel Radius Inches (mm)	Attach. Bolt Inches (mm)	Approx. Shipping Wt.		Swivel Caster	Rigid Caster
										Swivel lbs. (KGS)	Rigid lbs. (KGS)		
10 (254)	4 (102)	Forged Steel	88	Tapered Roller	1 1/4 (32)	30000 (22)	14 3/4 (375)	8 1/4 (210)	3/4 (19)	112 (51)	92 (42)	SKP13104T-FS	RKP13104T-FS
		Mold-on Rubber (Cast Iron Core)	74	Tapered Roller		2800 (1272)				110 (50)	90 (41)	SKP13104T-MR	RKP13104T-MR
		Polyurethane (Cast Iron Core)	78	Tapered Roller		8400 (3818)				111 (50)	91 (41)	SKP13104T-PI	RKP13104T-PI
		Severe Duty Polyurethane	79	Tapered Roller		8400 (3818)				116 (53)	96 (44)	SKP13104T-PS	RKP13104T-PS
12 (305)	4 (102)	Mold-on Rubber (Cast Iron Core)	74	Tapered Roller	1 1/4 (32)	3200 (1454)	15 3/4 (400)	9 1/4 (235)	3/4 (19)	118 (54)	98 (45)	SKP13124T-MR	RKP13124T-MR
		Polyurethane (Cast Iron Core)	78	Tapered Roller		9600 (4363)				120 (55)	100 (45)	SKP13124T-PI	RKP13124T-PI
		Severe Duty Polyurethane	79	Tapered Roller		9600 (4363)				125 (57)	105 (48)	SKP13124T-PS	RKP13124T-PS
	4 1/2 (127)	Press-on Polyurethane	N/A	Tapered Roller		6600 (3000)				130 (59)	110 (50)	SKP131245T-PO	RKP131245T-PO
	5 (127)	Polyurethane (Cast Iron Core)	78	Tapered Roller		12000 (6000)				134 (61)	114 (52)	SKP13125T-PI	RKP13125T-PI
	6 (152)	Polyurethane (Cast Iron Core)	78	Tapered Roller		15000 (6818)				146 (66)	126 (57)	SKP13126T-PI	RKP13126T-PI
16 (305)	4 (102)	Mold-on Rubber (Cast Iron Core)	74	Tapered Roller	1 1/4 (32)	3980 (1809)	19 3/4 (501)	12 1/2 (318)	3/4 (19)	140 (64)	120 (55)	SKP13164T-MR	RKP13126TMR
		Polyurethane (Cast Iron Core)	78	Tapered Roller		11940 (5427)				148 (67)	128 (58)	SKP13164T-PI	RKP13164T-PI
	5 (127)	Mold-on Rubber (Cast Iron Core)	74	Tapered Roller		5140 (2336)				150 (68)	130 (59)	SKP13165T-MR	RKP13165T-MR
	Polyurethane (Cast Iron Core)	78	Tapered Roller	15400 (7000)		156 (71)				136 (62)	SKP13165T-PI	RKP13165T-PI	
18 (457)	5 (127)	Mold-on Rubber (Cast Iron Core)	74	Tapered Roller	1 1/4 (32)	5600 (2545)	22 (559)	14 1/4 (362)	3/4 (19)	180 (82)	160 (73)	SKP13185T-MR	RKP13185T-MR
		Polyurethane (Cast Iron Core)	78	Tapered Roller		16800 (7636)				185 (84)	165 (75)	SKP13185T-PI	RKP13185T-PI
	9 (229)	Press-on Polyurethane	N/A	Tapered Roller		20000 (9090)		210 (95)		190 (86)	SKP13189T-PO	RKP13189T-PO	