

GAS SPRINGS



How Gas Springs Add Value

- Improves performance and ergonomics.
- Enhances safety. Controls opening and closing speeds.
- Designed to last the lifetime of most products.
- Totally self contained. Clean. Maintenance free.
- Manufactured in ISO9001 certified facility - Quality guaranteed.
- Cost effective answer to positioning moving parts.
- Lifts and compensates for weight.
- Infinite adjustment positions.

Common Uses For Gas Springs

- Printer sound enclosures.
- Deli case glass, displays, food processing equipment.
- Keyboard positioning and student desk lids.
- Positioning for hospital beds.
- Fitness equipment adjustments.
- Automotive, recreational, agricultural, construction vehicle, aircraft, and related accessories.
- Ergonomic office accessories and work stations.
- Medical and diagnostic apparatus, exam and birthing tables, hospital beds, stretchers, wheelchairs, and emergency equipment.
- Your next project!



How Gas Springs Work

- Inert gas is sealed in a roll-closed cylinder at specific pressure to provide output force.
- Oil is metered through labyrinth piston to provide smooth, controlled action.
- End fitting on tubes and rod permit easy attachment to your product.
- Some gas springs offer locking options.
- Caster-Pro has cables and actuators to provide "one source" of supply.

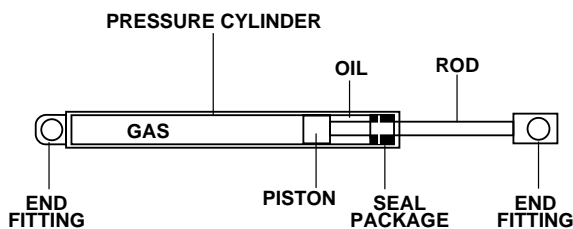

GAS SPRINGS

Technical Data



Lift-O-Mat®

Bloc-O-Lift®

Stab-O-Mat®

Proven and Reliable

Gas springs are a proven and reliable method of counterbalancing large covers and objects. They offer ideal capabilities for safely lifting, lowering and positioning heavy or cumbersome objects. More versatile than mechanical springs, gas springs offer your product the advantages of speed-controlled dampening, cushioned end motion, simple mounting, compact size, flat force curve, and a wide range of available forces.

Simple Construction

Essentially, a gas spring is a sealed cylinder consisting of only a few basic components: rod, tube, piston, seals and end attachments. It contains pressurized inert gas and a small amount of oil. Although we use standard components, we custom design and manufacture each product to meet specific needs.

Simple Operation

The internal pressure of the gas spring greatly exceeds atmospheric pressure. This pressure differential exists at any rod position and generates an outward force according to the equation:

$$\text{Force} = (P_{gs} - P_{atm}) \times (\text{rod area})$$

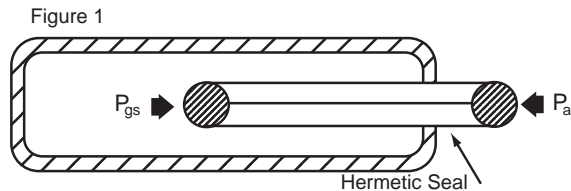

As the rod is pushed into the tube chamber, some of the gas volume is displaced, slightly increasing the internal pressure... P_{gs}. This causes forces to be a function of stroke as shown in figure 2. Actual gas spring forces are also governed by frictional effects (both static and dynamic).

Repeatable Linear Forces

Output forces of a gas spring are factory-set to customer specifications. Each gas spring is pressurized to obtain the desired working force P₁ and dependent forces P₂, P₃ and P₄.

As shown by the diagram in figure 2, when an external compressing force exceeds the extended force of a gas spring (P₃), the rod compresses into the cylinder. When the extension force (P₂) exceeds the external force applied, the gas spring extends. Frictional effects are represented by f.

The slope of the Force/Stroke diagram is represented by P₂/P₁ which is termed a Force Ratio. This can be varied from 1.1 to 1.6 in a given spring, depending on application requirements. Standard gas springs have Force Ratios typically ranging from 1.2 to 1.4.

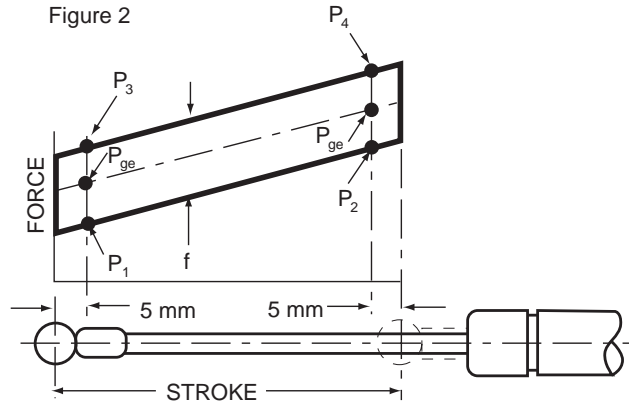

Dampening

During motion of the piston through the tube, versatile dampening capabilities are generated by forcing the gas and oil to meter through the piston.

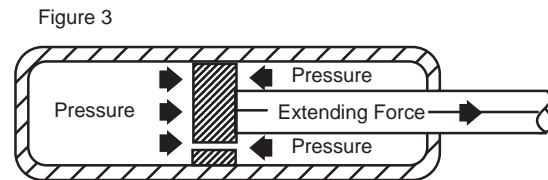

Our patented Labyrinth pistons use a "maze" path to generate variable degrees of dampening depending on the effective length of the maze. This allows the Labyrinth path cross-section to be larger, ensuring more reliable operation than tiny single-orifice pistons.

When the piston changes direction, the piston seal flips and can change the flow path through which the gas and oil pass. Most gas springs dampen during extension for controlled opening motion, but they bypass dampening during compression for easier closing. Compression dampening is optional.

Most applications perform more smoothly if the gas spring is oriented with its rod end down. This allows the more effective oil dampening to occur later to provide end cushioning.

Dampers for speed control only, without counter-balancing, are also available. Basic construction is essentially the same as the gas spring except there is much more dampening oil and no internal pressure charge. Dampening in widely variable amounts can then be provided in extension, compression or both directions.

GAS SPRINGS

Lift-O-Mat®

- Assists lifting, lowering and counter balancing
- Compact, self-contained
- Safely and economically controls motion
- Immediately available from stock

8 x 18 LIF T-O-MAT GAS SPRINGS

A Stroke Length mm (in.)	B Extend Length mm (in.)	P ₁ N (lbs)	Part No.
80 (3.15)	245 (9.65)	100 (22.5)	752614
		150 (33.7)	752622
		200 (44.9)	1417EP
		250 (56.2)	752630
		300 (67.5)	1418EK
		350 (78.7)	1419EF
100 (3.94)	285 (11.22)	400 (89.9)	752649
		500 (112.4)	752657
		600 (134.9)	752665
		100 (22.5)	752673
		150 (33.7)	752681
		200 (44.9)	1421EM
120 (4.72)	325 (12.80)	250 (56.2)	752703
		300 (67.5)	1422EH
		350 (78.7)	1423EC
		400 (89.9)	752711
		500 (112.4)	752738
		600 (134.9)	752746
160 (6.30)	405 (15.94)	150 (33.7)	752762
		200 (44.9)	1424EY
		250 (56.2)	752770
		300 (67.5)	1425ET
		350 (78.7)	1426EO
		400 (89.9)	752789
200 (7.87)	485 (19.09)	500 (112.4)	752797
		600 (134.9)	752800
		100 (22.5)	752819
		150 (33.7)	752827
		200 (44.9)	1427EJ
		250 (56.2)	752835
250 (9.84)	585 (23.03)	300 (67.5)	1428EE
		350 (78.7)	1431EG
		400 (89.9)	752843
		500 (112.4)	752851
		600 (134.9)	752878
		100 (22.5)	752886
300 (11.81)	685 (26.97)	150 (33.7)	752894
		200 (44.9)	1432EB
		250 (56.2)	752908
		300 (67.5)	1433EX
		350 (78.7)	1434ES
		400 (89.9)	752916
350 (13.78)	785 (30.91)	500 (112.4)	752924
		600 (134.9)	752932
		100 (22.5)	752940
		150 (33.7)	752959
		200 (44.9)	1435EN
		250 (56.2)	752967
400 (15.75)	885 (34.84)	300 (67.5)	1436EI
		350 (78.7)	1437ED
		400 (89.9)	752975
		500 (112.4)	752983
		600 (134.9)	752991

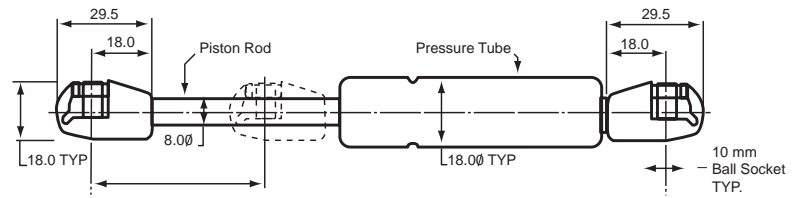

Specifications:

- D₁: Rod diameter
- D₂: Cylinder diameter
- C: 5mm
- x: force ratio = 1.35
- Friction force (FR MAX) in newtons 8x18=60
- 10x22=80

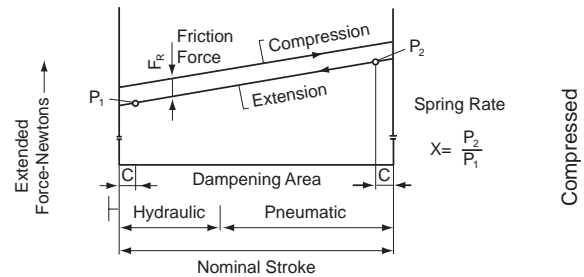

10 X 22 LIFT-O-MAT® GAS SPRINGS

A Stroke Length mm (in.)	B Extend Length mm (in.)	P ₁ N (lbs)	Part No.
200 (7.87)	485 (19.09)	700 (157.4)	1442EW
		800 (179.9)	1443ER
		900 (202.3)	1444EM
250 (9.84)	585 (23.03)	1000 (224.8)	1445EH
		700 (157.4)	1446EC
		800 (179.9)	1447EY
300 (11.81)	685 (26.97)	900 (202.3)	1448ET
		1000 (224.8)	1449EO
		250 (56.2)	1438EZ
350 (13.78)	785 (30.91)	400 (89.9)	753009
		700 (157.4)	753017
		900 (202.3)	753025
		1000 (224.8)	753033
		250 (56.2)	1439EU
		400 (89.9)	753041
400 (15.75)	885 (34.84)	700 (157.4)	753068
		900 (202.3)	753076
		1000 (224.8)	753084
		250 (56.2)	1441EA
		400 (89.9)	753092
		700 (157.4)	753106
400 (15.75)	885 (34.84)	900 (202.3)	753114
		1000 (224.8)	753122

GAS SPRINGS

Stab-O-Mat®

PNEUMATIC CHAIR HEIGHT ADJUSTMENT
WITH LIFETIME WARRANTY!*

- Immediate availability from stock
- Fits chairs of all sizes and types
- Meets or exceeds ANSI/BIFMA, GSA, and other standards
- Manufactured in ISO9001, North American factory
- Compatible with most chair bases
- Environmentally friendly black oxide, and chrome finishes available



***LIMITED WARRANTY INFORMATION AVAILABLE UPON REQUEST**

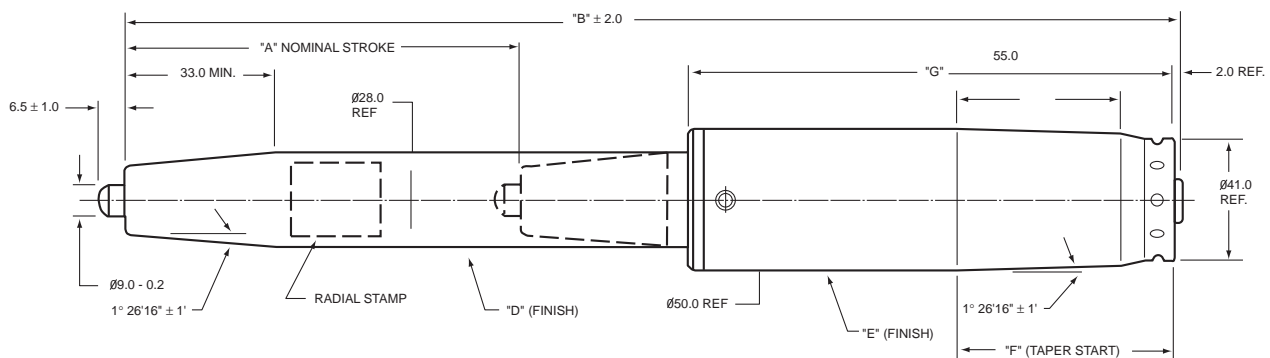

P/N	F1	A	B	D (FINISH)	E (FINISH)	F	G	PCS/PALLET
5024EU	300N	264.5	693.0	CHROME	BRIGHT CHROME	70.0	387.5	160
5023EZ	300N	264.5	693.0	BLACK OXIDE	BLACK PAINT	70.0	387.5	160
5022ED	300N	201.5	566.0	CHROME	BRIGHT CHROME	72.0	321.5	170
5021EI	300N	201.5	566.0	BLACK OXIDE	BLACK PAINT	75.0	318.5	170
2871EA	300N	135.5	413.0	BLACK OXIDE	BLACK PAINT	98.0	234.5	240
2874EM	300N	135.5	413.0	BLACK OXIDE	BLACK PAINT	76.0	234.5	240
5019EB	350N	120.5	395.0	BLACK OXIDE	BLACK PAINT	70.0	217.0	240
2868EZ	400N	95.5	340.0	BLACK OXIDE	BLACK PAINT	77.0	201.5	280
2867ED	400N	75.5	302.0	BLACK OXIDE	BLACK PAINT	74.0	189.5	310

GAS SPRINGS

Bloc-O-Lift®

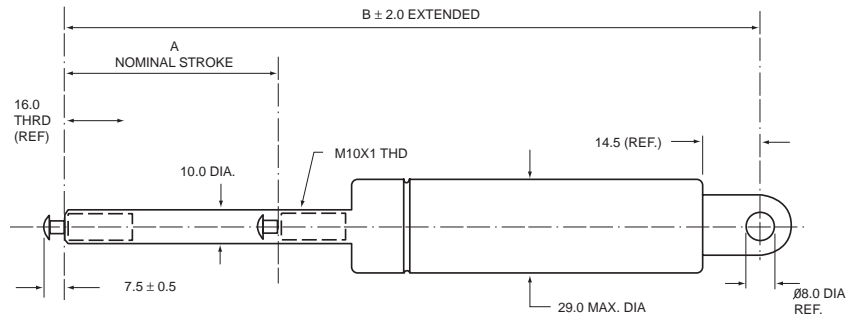

BLOC-O-LIFT® Elastic Locking Gas Spring

A Stroke Length mm(in.)	B Extend Length mm(in.)	P ₁ N (lbs)	Part No.
60 (2.35)	228 (8.98)	200 (45.0)	681865
		250 (56.2)	729345
		300 (67.4)	729353
		350 (78.7)	729361
		400 (89.9)	729388
		500 (112.4)	691933
		600 (134.9)	729396
		800 (179.9)	691941
		1000 (224.8)	729418
		1200 (269.8)	729426
80 (3.15)	269 (10.59)	200 (45.0)	681946
		250 (56.2)	729434
		300 (67.4)	729442
		350 (78.7)	729450
		400 (89.9)	729469
		500 (112.4)	691968
		600 (134.9)	729477
		800 (179.9)	691976
		1000 (224.8)	729485
		1200 (269.8)	729493
100 (3.94)	310 (12.20)	200 (45.0)	681873
		250 (56.2)	729507
		300 (67.4)	729515
		350 (78.7)	729523
		400 (89.9)	729531
		500 (112.4)	691984
		600 (134.9)	729558
		800 (179.9)	691992
		1000 (224.8)	729566
		1200 (269.8)	729574
120 (4.72)	348 (13.70)	200 (45.0)	681881
		250 (56.2)	729582
		300 (67.4)	729590
		350 (78.7)	729604
		400 (89.9)	729612
		500 (112.4)	692018
		600 (134.9)	729620
		800 (179.9)	692026
		1000 (224.8)	729639
		1200 (269.8)	729647
160 (6.30)	430 (16.93)	200 (45.0)	681903
		250 (56.2)	729655
		300 (67.4)	729663
		350 (78.7)	729671
		400 (89.9)	729698
		500 (112.4)	692034
		600 (134.9)	729701
		800 (179.9)	692212
		1000 (224.8)	729728
		1200 (269.8)	729736
200 (7.87)	509 (20.04)	200 (45.0)	681911
		250 (56.2)	729744
		300 (67.4)	729752
		350 (78.7)	729760
		400 (89.9)	729779
		500 (112.4)	692220
		600 (134.9)	729787
		800 (179.9)	692239
		1000 (224.8)	729795
		1200 (269.8)	729809
250 (9.84)	610 (24.02)	200 (45.0)	682938
		250 (56.2)	729817
		300 (67.4)	729825
		350 (78.7)	729833
		400 (89.9)	729841
		500 (112.4)	692247
		600 (134.9)	729868
		800 (179.9)	692255
		1000 (224.8)	729876
		1200 (269.8)	729884

BLOC-O-LIFT® Rigid Locking Gas Spring

A Stroke Length mm (in.)	B Extend Length mm (in.)	P ₁ N(lbs)	FE N(lbs)	FC N(lbs)	Part No.
60 (2.36)	265 (10.43)	200 (45.0)	10500 (2369)	500 (112)	682829
		250 (56.2)	10000 (2248)	1000 (225)	731943
		300 (67.4)	9500 (2136)	1000 (225)	731951
		350 (78.7)	9000 (2023)	1500 (337)	731978
		400 (89.9)	8500 (1911)	2000 (450)	731986
		500 (112.4)	7500 (1686)	2500 (567)	692948
		600 (134.9)	6500 (1461)	3000 (674)	731994
		800 (179.9)	4500 (1012)	4000 (899)	692956
		1000 (224.8)	2000 (450)	5000 (1124)	732001
		80 (3.15)	310 (12.20)	200 (45.0)	10500 (2369)
250 (56.2)	10000 (2248)			1000 (225)	732028
300 (67.4)	9500 (2136)			1000 (225)	732036
350 (78.7)	9000 (2023)			1500 (337)	732044
400 (89.9)	8500 (1911)			2000 (450)	732052
500 (112.4)	7500 (1686)			2500 (567)	692964
600 (134.9)	6500 (1461)			3000 (674)	732060
800 (179.9)	4500 (1012)			4000 (899)	692972
1000 (224.8)	2000 (450)			5000 (1124)	732079
100 (3.94)	370 (14.57)			200 (45.0)	10500 (2369)
		250 (56.2)	10000 (2248)	1000 (225)	732087
		300 (67.4)	9500 (2136)	1000 (225)	732095
		350 (78.7)	9000 (2023)	1500 (337)	732109
		400 (89.9)	8500 (1911)	2000 (450)	732117
		500 (112.4)	7500 (1686)	2500 (567)	692980
		600 (134.9)	6500 (1461)	3000 (674)	732125
		800 (179.9)	4500 (1012)	4000 (899)	692999
		1000 (224.8)	2000 (450)	5000 (1124)	732133
		120 (4.72)	420 (16.54)	200 (45.0)	10500 (2369)
250 (56.2)	10000 (2248)			1000 (225)	732141
300 (67.4)	9500 (2136)			1000 (225)	732168
350 (78.7)	9000 (2023)			1500 (337)	732176
400 (89.9)	8500 (1911)			2000 (450)	732184
500 (112.4)	7500 (1686)			2500 (567)	692980
600 (134.9)	6500 (1461)			3000 (674)	732192
800 (179.9)	4500 (1012)			4000 (899)	693014
1000 (224.8)	2000 (450)			5000 (1124)	732206
160 (6.30)	510 (20.08)			200 (45.0)	10500 (2369)
		250 (56.2)	10000 (2248)	1000 (225)	732273
		300 (67.4)	9500 (2136)	1000 (225)	732281
		350 (78.7)	9000 (2023)	1500 (337)	732303
		400 (89.9)	8500 (1911)	2000 (450)	732311
		500 (112.4)	7500 (1686)	2500 (567)	693022
		600 (134.9)	6500 (1461)	3000 (674)	732338
		800 (179.9)	4500 (1012)	4000 (899)	693030
		1000 (224.8)	2000 (450)	5000 (1124)	732346
		200 (7.87)	600 (23.62)	200 (45.0)	10500 (2369)
250 (56.2)	10000 (2248)			1000 (225)	732354
300 (67.4)	9500 (2136)			1000 (225)	732362
350 (78.7)	9000 (2023)			1500 (337)	732370
400 (89.9)	8500 (1911)			2000 (450)	732389
500 (112.4)	7500 (1686)			2500 (567)	693049
600 (134.9)	6500 (1461)			3000 (674)	732397
800 (179.9)	4500 (1012)			4000 (899)	693057
1000 (224.8)	2000 (450)			5000 (1124)	732400
250 (9.84)	730 (28.74)			200 (45.0)	10500 (2369)
		250 (56.2)	10000 (2248)	1000 (225)	732419
		300 (67.4)	9500 (2136)	1000 (225)	732427
		350 (78.7)	9000 (2023)	1500 (337)	732435
		400 (89.9)	8500 (1911)	2000 (450)	732443
		500 (112.4)	7500 (1686)	2500 (567)	693065
		600 (134.9)	6500 (1461)	3000 (674)	732451
		800 (179.9)	4500 (1012)	4000 (899)	693073

FE=Locking force in extension direction FC=Locking force in compression direction

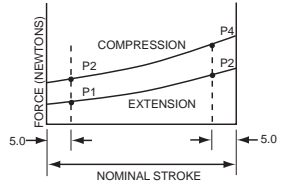
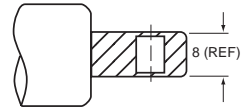

- Infinite adjustment of positions
- Rigid (positive) or Elastic (cushioned) locking
- Counter balances forces



MINIMUM ORDER REQUIREMENTS!
MUST BE SPECIFICALLY ASSEMBLED FOR EACH PROJECT

See next pages for:

- Cables
- Actuators
- Operations
- Accessories

GAS SPRINGS

Options & Accessories

- OTHER GAS SPRINGS
- END FITTINGS
- MOUNTING HARDWARE

CUSTOM GAS SPRINGS

STAB-O-SHOC®



- Linear speed control
- Dampens in compression, extension, or both directions.
- Available with or without output forces.

HYDRO-LIFT®



- Assist opening.
- Stays in any position until operator indexes to a new position.

LIFT-N-LATCH®



- Safely assist opening effort.
- Locks in open position. Assures object remains open.
- Close by pressing safety release.

END FITTINGS



COMPOSITE SOCKETS
(standard)



STEEL SOCKET & CLIP
(special order)



STEEL BLADE
(special order)

MOUNTING HARDWARE

In Stock for Immediate Shipment

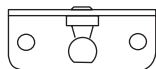

**SL-46P3R-1
L.H. BRACKET**
(38.5 mm C-C)

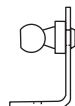

**SL-46P3-1
R.H. BRACKET**
(38.5 mm C-C)

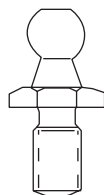
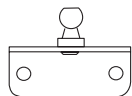

STANDARD BALL STUD
5/16-18 102431
M8 022721

**SL-3-HP3
BRACKET**
(36.5 mm C-C)

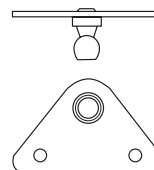

**13 MM
BALL STUD**
(special)

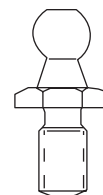

GAS SPRINGS

Accessories

- Engineered to operate Bloc-O-Lift® gas springs
- Combine with any product requiring remote actuation

REMOTE ACTUATION SYSTEMS



11603

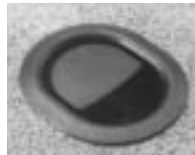

11605



12074



11767



11764



11604



12129



12073



11602-10



12030-10



12076-10



11708-10



12075-10



12077



81-222P



99

CABLE ASSEMBLY



Shuttle molded cable control assemblies can be made in any length to suit your application. The final design is based on the actuator, operator or mechanism you select for each end of the assembly and the length you require.

MINIMUM ORDER REQUIREMENTS!
MUST BE SPECIFICALLY ASSEMBLED FOR EACH PROJECT